

HENNEPIN COUNTY
CONSULTING SERVICES PROGRAM

**MASTER AGREEMENT
FOR PROFESSIONAL CONSULTING SERVICES**

August 2020

TABLE OF CONTENTS

SECTION 1. TERM OF AGREEMENT 3

SECTION 2. CONSIDERATION OF CONSULTANTS FOR WORK 3

SECTION 3. AUTHORIZATION TO PERFORM SERVICES ON A PROJECT 4

SECTION 4. PERIOD OF PERFORMANCE 4

SECTION 5. ADMINISTRATION AND SUPERVISION 5

SECTION 6. RESPONSIBILITY OF THE CONSULTANT 8

SECTION 7. SPECIFICATIONS 10

SECTION 8. SERVICES AND DATA TO BE FURNISHED TO CONSULTANT BY
THE COUNTY 10

SECTION 9. PAYMENT TO CONSULTANT 11

SECTION 10. DEFAULT AND CANCELLATION/TERMINATION AND SUBMITTAL OF
CONTRACT DOCUMENTS 15

SECTION 11. DATA PRACTICES 17

SECTION 12. NON-DISCRIMINATION 17

SECTION 13. AFFIRMATIVE ACTION 17

SECTION 14. SMALL BUSINESS ENTERPRISE PROGRAM 18

SECTION 15. INSPECTION OF WORK AND DOCUMENTS 18

SECTION 16. SUCCESSORS, NON-ASSIGNMENT AND SUBCONTRACTING 18

SECTION 17. BROKERAGE FEE 19

SECTION 18. INDEPENDENT CONTRACTOR 19

SECTION 19. INDEMNIFICATION AND INSURANCE 20

SECTION 20. OWNERSHIP OF DOCUMENTS 22

SECTION 21. FURNISHING OF INFORMATION TO THE COUNTY 23

SECTION 22. RECORDS – AVAILABILITY/ACCESS 23

SECTION 23. CONTINUATION OF OBLIGATION 23

SECTION 24. MERGER AND MODIFICATION 23

SECTION 25. PAPER RECYCLING 24

SECTION 26. USE OF CONTRACT BY OTHER METRO-AREA COUNTIES 24

SECTION 27. MISCELLANEOUS 24

SECTION 28. LIST OF EXHIBITS AND APPENDICES 25

**MASTER AGREEMENT FOR
PROFESSIONAL CONSULTING SERVICES**

THIS AGREEMENT, made and entered into this _____ day of _____, 20____, by and between the County of Hennepin, State of Minnesota, hereinafter referred to as "COUNTY", A-2300 Government Center, Minneapolis, Minnesota, 55487, and _____ hereinafter referred to as "CONSULTANT," a _____ organized under the laws of the state of _____ whose principal place of business is:

_____.

WITNESSETH:

WHEREAS, The COUNTY may engage CONSULTANT to provide professional consulting services within one or more of the professional disciplines, hereinafter referred to as "Work Types", as listed in "Consulting Services Program Application" (Exhibit A); and

WHEREAS, The COUNTY creates a roster of consultants within each Work Type pursuant to its Consulting Services Program ("CSP"); and

WHEREAS, CONSULTANT acknowledges that it may be considered for a Hennepin County project only if it appears on the roster prepared by the COUNTY within the Work Type(s) associated with such County project; and

WHEREAS, The COUNTY and CONSULTANT enter this Master Agreement for Professional Consulting Services with the understanding that the Agreement is not a guarantee of work nor a guarantee of minimum compensation.

NOW THEREFORE, IT IS HEREBY AGREED:

SECTION 1. TERM OF AGREEMENT

The term of this Agreement shall be for sixty (60) months from the date stated above, except as provided for in this Agreement.

SECTION 2. CONSIDERATION OF CONSULTANTS FOR WORK

- A. CONSULTANT's opportunity to provide professional consulting services to the COUNTY under this Agreement is based on CONSULTANT appearing on the roster for one or more Work Types established under the CSP.
- B. For purposes of selecting a consultant to be solicited for a proposal, the COUNTY will classify a project in terms of a primary work type. Firms appearing on the roster for the primary work type will be considered for solicitation for the project by the COUNTY's Project Manager in accordance with the COUNTY's guidelines for consultant selection.

- C. Consultants who are solicited for a Project may submit a proposal for the Project which includes: a detailed scope of work; a work plan; and a project schedule. The proposal shall identify the firm's proposed Project Team, including identifying its "Key Personnel" (professional level staff as well as licensed, certified and/or accredited professionals); also including any Key Personnel of subconsultant members of the team, who must be clearly identified.
1. If the proposal will be evaluated on both cost and non-cost factors, firms will be required to submit a scope of work including: the estimated number of hours allocated among the personnel comprising the Project Team, including the personnel of subconsultants; the billing rate schedule for such personnel, including the billing rate of personnel of subconsultants; and any anticipated Project expenses.
 2. If the consultant is to be selected pursuant to a Qualifications-Based Selection (QBS) process, then cost data will not be requested as part of the initial proposal but will be requested from the firm that is the highest ranked qualified firm.

The COUNTY's Project Manager will inform consultants solicited for the Project whether the consultant selection process will be QBS or will include consideration of cost.

SECTION 3. AUTHORIZATION TO PERFORM SERVICES ON A PROJECT

- A. The COUNTY's Project Manager will notify CONSULTANT in writing when it is selected for work on a Project. CONSULTANT will be authorized to perform such work through a Consulting Services Authorization (marked as "Exhibit B" hereto and incorporated by this reference) and a Purchase Order number, which shall be issued by a Project Manager during the term of this Agreement. The Consulting Services Authorization will be based on and will incorporate the final negotiated scope of work for the Project.
- B. Modifications to the scope of work may be authorized by the COUNTY's Project Manager during CONSULTANT's authorized period of performance, through a "Consulting Services Authorization Amendment" (marked as "Exhibit C" hereto and incorporated by this reference) as provided in this Agreement.

SECTION 4. PERIOD OF PERFORMANCE

A. Starting Work

CONSULTANT shall not start work on a Project prior to the COUNTY's issuance of a Consulting Services Authorization covering such work. The COUNTY will not issue a Consulting Services Authorization for work to commence after the expiration date of this Agreement.

B. Time Completion Period

Time is a material consideration in the performance of all work by CONSULTANT under this Agreement. CONSULTANT shall complete its work and services within the schedule included in the scope of work upon which the Consulting Services Authorization is issued, including all milestones and task completion dates included therein.

C. Schedule Modifications

The completion dates for tasks listed in the proposal may be modified by a Consulting Services Authorization Amendment; however, the contract milestones specified in the schedule shall not be extended because of an unwarranted delay attributable to CONSULTANT. The contract milestones may be extended in the event of a delay caused by the COUNTY which results in a delay in the performance of an affected task, because of unavoidable delay caused by any governmental action, or other conditions beyond the control of CONSULTANT, which could not be reasonably anticipated, and which result in a delay in the contract milestones.

D. Cost Impact of Avoidable Delays

The maximum amount of compensation (fees & reimbursable expenses) authorized under a Consulting Services Authorization shall not be increased because of any unwarranted delays in the completion of contract milestones attributable to CONSULTANT. In the event of a delay in the completion of contract milestones over which CONSULTANT has no control and that results in an increase in costs to perform the work, the COUNTY may, through the issuance of a Consulting Services Authorization Amendment, adjust the budget for specific tasks and/or the total compensation.

E. Completion of Work

All work and services authorized under this Agreement must be completed no later than one year following the expiration date of this Agreement.

SECTION 5. ADMINISTRATION AND SUPERVISION

A. COUNTY

1. Hennepin County staff shall administer this Agreement on behalf of the COUNTY.
 - a. The Consulting Services Program Manager shall perform day-to-day management of this Agreement in respect to CONSULTANT's appearing on the roster within one or more Work Types established under the CSP.
 - b. To coordinate the services of CONSULTANT with the applicable county department that is to receive CONSULTANT's services, such county department will designate a person, or their successor, (the "Project Manager") for each Consulting Services Authorization issued for a Project, who will serve as the principal liaison between the COUNTY and the CONSULTANT in respect to such Project.
 - c. The Project Manager shall administer this Agreement on behalf of the COUNTY in respect to the Project and will be responsible for the following:
 - (1) Directly selecting a firm from the roster for a Project or issuing a Consulting Services Solicitation Request (either the cost-based version, marked as

Exhibit D-1 or the QBS version, marked as Exhibit D-2, both attached hereto and incorporated by this reference) to listed firms within the Work Type of the Project;

- (2) Issuing a Consulting Services Authorization to the firm selected for the Project;
 - (3) Approving CONSULTANT's payment invoices;
 - (4) Approving modifications to a Consulting Services Authorization through a Consulting Services Authorization Amendment; and
 - (5) Determining when CONSULTANT has satisfactorily performed all work and ensuring that CONSULTANT complies with the provisions of this Agreement.
- d. A Consulting Services Authorization Amendment will be issued to authorize the following modifications to the Scope of Work upon which a Consulting Services Authorization is issued:
- (1) Substituting Key Personnel that are listed on the Project Team;
 - (2) Adding or removing subconsultants;
 - (3) Modifying the Project Schedule;
 - (4) Modifying the services or tasks to be performed by CONSULTANT or a subconsultant;
 - (5) Adjusting amounts for defined tasks within the Project Budget, without increasing the authorized not-to-exceed amount for total compensation; and
 - (6) Increasing CONSULTANT's authorized not-to-exceed amount for total compensation.

B. CONSULTANT

1. CONSULTANT represents that it has, or will obtain, all personnel necessary to perform the services required under this Agreement and that such personnel shall be qualified, experienced and licensed as may be necessary or required by laws and regulations to perform such services. All services required under this Agreement shall be performed by CONSULTANT, its Project Team, or by subconsultants whose inclusion in a Project has been expressly authorized by the COUNTY, as described below. The COUNTY's authorization for the inclusion of a subconsultant in a Project does not relieve CONSULTANT of any duties or obligations under this Agreement or at law to perform in a satisfactory and competent manner.
2. Authorized Subconsultants
 - a. CONSULTANT may perform the services required under this Agreement through a subconsultant that is not on the CSP roster.

- b. The scope of work upon which the Consulting Services Authorization is issued must include the following information with respect to any subconsultant who will perform services on the Project:
 - (1) The name of subconsultant's firm;
 - (2) The names and qualifications of subconsultant's Project Team who will be providing services;
 - (3) The responsibilities/tasks of the sub-consultant; and
 - (4) The subconsultant's total compensation (fees and reimbursable expenses), which shall also be stated as a percentage of CONSULTANT's total compensation.

3. Process for Adding or Removing Subconsultants

If CONSULTANT wishes to add or remove a subconsultant during the period of performance authorized by a Consulting Services Authorization, CONSULTANT must provide the Project Manager with a written request for the proposed change that includes the following information:

- a. Name of the subconsultant firm to be added and/or replaced, and the work to be performed;
- b. Resumes and documentation outlining the subconsultant's relevant experience as well as the relevant experience of its Key Personnel;
- c. Proposed subconsultant's total cost, identifying direct labor costs (labor rate or billing rate), indirect costs, other direct costs, and/or fixed professional fee; and
- d. If the proposed subconsultant is to perform work of CONSULTANT or another subconsultant already identified in the scope of work, an explanation of why CONSULTANT proposes to transfer such work to a new subconsultant.

4. COUNTY Approval of Subconsultants

Before any subconsultant not already identified in the scope of work upon which the Consulting Services Authorization was issued can perform work on the Project, the COUNTY must provide written authorization through a Consulting Services Authorization Amendment. Such authorization shall not be unreasonably withheld.

5. Separation of CONSULTANT's Key Personnel from the Firm

CONSULTANT hereby acknowledges the following:

That the COUNTY's consideration of and/or selection of CONSULTANT for Projects is based on the availability and inclusion of specific CONSULTANT's Key Personnel among CONSULTANT's Project Team identified in the proposal.

Therefore, CONSULTANT agrees to notify COUNTY's Project Manager in writing when Key Personnel identified in CONSULTANT's proposal and scope of work for the project are no longer affiliated with CONSULTANT, not later than ten (10) days following such Key Personnel's separation from CONSULTANT's firm.

CONSULTANT shall submit the following information to the Project Manager:

- a. experience and qualifications of additional or replacement Key Personnel necessary to fulfill the scope of work identified in the Consulting Services Authorization for the project.
- b. billing rate schedule for the additional or replacement Key Personnel.

The Project Manager will authorize the replacement of Key Personnel through the issuance of a Consulting Services Authorization Amendment.

6. Removal of CONSULTANT Personnel

CONSULTANT shall remove from a Project any employee when the COUNTY considers such removal necessary and in the best interests of the Project. CONSULTANT shall also take appropriate steps when the COUNTY communicates a concern about the services of any subconsultant. Removal of CONSULTANT personnel either at the county's request or at CONSULTANT's discretion and any costs associated with the "Transfer of Knowledge and Information" between its personnel shall be the responsibilities of CONSULTANT. "Transfer of Knowledge and Information" includes, but is not limited to, the labor hours spent reviewing project documentation; participating in meetings with CONSULTANT's other project personnel; meeting with the COUNTY Project Manager and other members of the COUNTY's Project Team; and participating in site visits to become familiar with the project location(s). The COUNTY shall not pay for any time spent by any member of CONSULTANT's Project Team, including subconsultants, involved in the "Transfer of Knowledge and Information".

7. Certification that CONSULTANT's invoices exclude prohibited "Transfer of Knowledge and Information" costs

Following the COUNTY's approval of a substitution of CONSULTANT's personnel for a project, CONSULTANT shall thereafter include with its invoices a written certification that the time associated with the "Transfer of Knowledge and Information" has not been billed to the COUNTY and is not a cost borne directly or indirectly by the COUNTY.

SECTION 6. RESPONSIBILITY OF THE CONSULTANT

- A. During performance under this Agreement, CONSULTANT shall make its best efforts to manage the Agreement such that work, and services are provided and performed in a cost-effective and efficient manner. CONSULTANT shall complete its work and services within the budget and schedule of the scope of work upon which a Consulting Services Authorization is issued.

- B. CONSULTANT shall perform its work in accordance with the requirements of this Agreement and pursuant to the standards of professional care, skill, diligence and competence as are normally exercised by other members and/or firms of the profession in good standing working under the same or similar conditions and circumstances. CONSULTANT shall be responsible for the professional standards, performance and actions of all persons and firms performing work pursuant to this Agreement on behalf of CONSULTANT.
- C. CONSULTANT must be familiar with the standards and specifications included within the definition of each Work Type for which it appears on the roster as well as the applicable Supplementary Technical Requirements. The COUNTY's Supplementary Technical Requirements prescribe computer-aided drafting & design standards and planning, design, and construction standards for architectural services. These Supplementary Technical Requirements are set forth in the following exhibits to this Agreement:
1. Exhibit F-1 Hennepin County Public Works Transportation Computer-Aided Design Drafting (CAD) Standards;
 2. Exhibit F-2 Hennepin County CAD Protocol for Facility Services Projects; and
 3. Exhibit F-3 Planning, Design and Construction Standards for Architectural Services.

Each of the aforesaid exhibits are attached hereto and are incorporated by this reference. CONSULTANT must perform all work and services in accordance with the Supplementary Technical Requirements applicable to the work type of the Project for which it is listed on the roster to perform work, and as these may be hereafter modified by COUNTY. If COUNTY modifies such Supplementary Technical Requirements, it shall provide notice to CONSULTANT of such modifications, at which time such modifications will become effective.

- D. CONSULTANT shall, without additional compensation, correct or revise any errors, omissions or other deficiencies in any plans, designs, drawings, specifications, reports and other deliverables not meeting CONSULTANT's professional standards of care, skill, diligence and competence for the work to be performed hereunder; and CONSULTANT shall be responsible to the COUNTY for any and all costs or damages incurred by the COUNTY resulting therefrom.
- E. The COUNTY's approval of plans, drawings, designs, specifications, reports and other products of the professional services rendered hereunder shall not in any way relieve CONSULTANT of responsibility for the technical adequacy or accuracy thereof. Neither the COUNTY's review, approval, acceptance of, and/or payment for any services shall be construed to operate as a waiver of any rights under this Agreement or of any cause of action arising out of the performance of this Agreement.
- F. CONSULTANT shall document the results of the work it performs to the satisfaction of the COUNTY. This shall include preparation of progress and final reports, plans and estimates, or similar evidence of attainment of the contract objectives. CONSULTANT shall incorporate this requirement in all subcontracts issued under this Agreement.
- G. When record documents are requested through a Consulting Services Authorization, such record documents shall consist of construction documents modified by

CONSULTANT based on information submitted by the constructor that reflect changes made during construction. CONSULTANT shall exercise professional care to verify the completeness of the constructor's marked-up prints, drawings, and other submissions, based on CONSULTANT's direct involvement with the work. Record documents must also conform to the Hennepin County Computer-Aided Drafting & Design Standards or Protocol prescribed for the Work Type associated with the Project.

- H. CONSULTANT shall confer with the COUNTY Project Manager, or such other COUNTY staff as designated by the COUNTY Project Manager, as often as is necessary to perform work authorized under this Agreement and with prior approval from the COUNTY Project Manager, shall perform the travel necessary to accomplish such work. Any request for reimbursement for CONSULTANT's travel expenses must conform to the provisions of Section 9 (Payment To Consultant) hereof.

SECTION 7. SPECIFICATIONS

- A. In the performance of this Agreement, CONSULTANT shall, to the extent practicable, design and draft specifications that provide for maximum use of structures, machines, products, materials, construction methods, and equipment that are readily available through competitive procurement and through standard or proven production techniques, methods and processes.
- B. Unless CONSULTANT has provided a written justification for the use of a single source and/or restrictive design or specification and the COUNTY provides written concurrence of such use, CONSULTANT shall not, in the performance of the work under this Agreement:
 - 1. Produce a design or specification that will require the use of structures, machines, products, materials, construction methods, equipment, or processes that CONSULTANT knows to be available only from a single source; and/or
 - 2. Produce a design or specification that will be restrictive or written in such a manner as to contain proprietary, exclusionary, or discriminatory requirements other than those based upon performance.
- C. When one or more brand names or trade names of comparable quality or utility are listed the words "or approved equal" shall follow the brand name(s) and the salient characteristics shall be identified.

SECTION 8. SERVICES AND DATA TO BE FURNISHED TO CONSULTANT BY THE COUNTY

A. Data and Material Furnished

After issuance of a Consulting Services Authorization, the COUNTY may furnish data and materials to CONSULTANT for its use in connection with the authorized work.

All data furnished to CONSULTANT by the COUNTY shall remain the property of the COUNTY and shall be returned to the COUNTY when so requested.

CONSULTANT furthermore acknowledges and agrees that any proprietary data that may be furnished by the COUNTY is the exclusive property of the COUNTY and shall be for the sole use of CONSULTANT, who shall not assert any right, title or interest in the proprietary data. CONSULTANT shall neither dispose, furnish, sell, transfer or disseminate the proprietary data to any other person, firm entity or organization unless specifically authorized in writing by the COUNTY.

B. Analysis and Evaluation of Data by CONSULTANT

Unless otherwise specified in the scope of work, CONSULTANT shall not be required to make an analysis and evaluation of all data and information furnished by the COUNTY but shall be able to rely on the accuracy and completeness of such data and information to the same extent other professionals in CONSULTANT's discipline would reasonably rely on such data and information. Notwithstanding the foregoing, if any data or information is found to be incorrect or incomplete by CONSULTANT, this fact should be brought to the attention of the COUNTY before proceeding further with the part of the Project affected thereby.

SECTION 9. PAYMENT TO CONSULTANT

A. Method of Payment

The COUNTY will compensate CONSULTANT for all work and services performed in accordance with this Agreement.

1. Billing Rate and Reimbursable Costs

- a. CONSULTANT's compensation for services provided under this Agreement shall be based on the actual hours worked at the individual labor rates reflected in the billable rate schedule that will be included in the scope of work upon which the Consulting Services Authorization is issued for a Project. Such rates will remain in effect until CONSULTANT completes the work described in the Consulting Services Authorization.
- b. Reimbursable Expenses are in addition to CONSULTANT's compensation and may include the following costs incurred by CONSULTANT and CONSULTANT's employees and approved subcontractors in the completion of the Project:
 - (1) expense of transportation in connection with out-of-town travel authorized in advance in writing by the COUNTY Department's Project Manager. Use of a personal automobile for out-of-town travel may be reimbursed at the current IRS reimbursement rate.;
 - (2) fees paid for securing approval of authorities having jurisdiction over the project; and
 - (3) expense of additional insurance coverage or limits, including professional liability insurance, requested by the COUNTY in excess of that normally

carried by CONSULTANT and CONSULTANT's approved subcontractors, if authorized in advance in writing by COUNTY.

No other reimbursable expenses are permitted unless expressly authorized in advance in writing by the Project Manager.

- c. CONSULTANT compensation shall not include costs attributed to additional services caused by CONSULTANT, its employees or subcontractors.
- d. No payment for any costs incurred by CONSULTANT shall be reimbursed by the COUNTY if the work has not been previously and specifically authorized by the COUNTY in the Consulting Services Authorization issued for the Project.
- e. Payments for all costs and fees incurred under the terms of this Agreement shall be made to CONSULTANT in accordance with the provisions hereof. Payment for work performed by approved subcontractors shall be the responsibility of CONSULTANT.

B. Total Payments

1. Subconsultant Costs

The cost of services of approved subconsultants shall be the multiple of one (1.0) times the amount invoiced to CONSULTANT unless expressly authorized prior to the commencement of subconsultant's performance, in the Consulting Services Authorization issued for the Project. Reimbursable expenses and other approved items and services must be charged to the COUNTY at a multiple of one (1.0) times CONSULTANT's cost.

2. Subconsultant Payment

As required by Minnesota Statutes Section 471.425, Subd. 4a, CONSULTANT shall pay any subconsultant within ten (10) days of CONSULTANT's receipt of payment from the COUNTY for undisputed services provided by the subconsultant. CONSULTANT shall pay interest of 1½ percent per month or any part of a month to the subconsultant on any undisputed amount not paid on time to the subconsultant. The minimum monthly interest penalty payment for an unpaid balance of \$100.00 or more is \$10.00. For an unpaid balance of less than \$100.00, CONSULTANT shall pay the actual penalty due to the subconsultant. A subconsultant who prevails in a civil action to collect interest penalties from a prime consultant must be awarded its costs and disbursements, including any attorney's fees, incurred in bringing the action.

3. Required Work and Services Outside the Scope of Work

- a. CONSULTANT is responsible for notifying the COUNTY in writing any time CONSULTANT believes the work and services required by the COUNTY are not within the scope of work upon which the Consulting Services Authorization was issued. CONSULTANT shall include with said notification an estimate of the costs involved to complete any such perceived additional work.

- b. In the event the COUNTY concurs that the work and services requested are not within the scope of work upon which the Consulting Services Authorization was issued, and the COUNTY desires CONSULTANT to perform said work and services, the COUNTY shall either issue a Consulting Services Authorization Amendment or new Consulting Services Authorization to cover the additional services.
- c. CONSULTANT acknowledges and hereby agrees that, if it fails to obtain a Consulting Services Authorization Amendment or new Consulting Services Authorization to cover the additional services, any costs or fees arising out of the performance of such additional work or services shall not be paid by the COUNTY but shall be borne completely and exclusively by CONSULTANT.

C. Invoices - Partial Payments

CONSULTANT shall submit signed monthly invoices not more often than once a month for reimbursement of costs incurred by CONSULTANT in the performance of its obligations under this Agreement during the previous month and shall submit such invoices not later than 60 days after the end of the month during which services were provided. All invoices submitted for payment shall include, but are not limited to, the following detailed information and shall contain the information (if applicable to the Project) in the attached "CSA Consultant Invoice Example", attached hereto as Exhibit E and hereby made a part of this Agreement.

1. An invoice header must include the date of the invoice, the invoice number, CONSULTANT's taxpayer identification number and the following information that is included in the Consulting Services Authorization issued for a Project:
 - Name and address of the county Project Manager
 - Project name and number
 - Contract number
 - Consulting Services Authorization designation and Purchase Order number
 - Amount of the authorization/Purchase Order.

Invoices and supporting documentation should be sent to the following central PO Box: Hennepin County Accounts Payable, PO Box 1388, Minneapolis, MN 55440-1388. Invoices can also be sent via email to obf.internet@hennepin.us.

Additional direction for invoice submittal may be included in the Consulting Services Authorization.

2. A payroll cost breakdown, which must identify CONSULTANT's employees and subcontractors separately, must include worker's name, job classification, billable rate, hours worked, amount, total payments and the invoice period.
3. Reimbursement for approved subcontractor costs and other direct costs shall be identified and supported with necessary documents to show that such costs are properly allocable to the Project.

4. The COUNTY will review invoices and payment shall be made within forty-five (45) days of the date of completion of the services or date of receipt of the invoice, whichever is later. Payment shall be made in the manner prescribed by law governing the COUNTY's payment of claims and/or invoices.

D. Final Payment

1. Final payment due CONSULTANT will be made by the COUNTY when all work and services have been performed and all studies, reports, layouts, plans, special provisions, and other documents, including electronic data files provided in the file format required by the applicable Hennepin County Computer Aided Drafting and Design Standards or Protocol (see Technical Requirements, Exhibits F-1 and F-2) have been delivered to the COUNTY in accordance with the provisions contained herein or as may be hereafter amended.
2. The COUNTY, in its sole and absolute discretion, may retain all or part of the final payment to assure that CONSULTANT completes and submits the Project record documents in accordance with the standards prescribed in Section 6.G hereof. The COUNTY does not waive any other rights or remedies it may have based on CONSULTANT's performance or nonperformance. CONSULTANT's contractual responsibility will not be considered complete until the COUNTY's acceptance is issued, and no additional fees will be considered for CONSULTANT's expenses of labor and/or passage of time in completing this aspect of the work. Following the COUNTY's acceptance, payments will be made to CONSULTANT as provided herein.
3. The COUNTY shall have the right to base the final payment due CONSULTANT on actual acceptable costs as determined by an audit conducted by the State of Minnesota, or the COUNTY, or other audits accepted by said agencies.

E. Conditions of Payment

1. All services provided by CONSULTANT pursuant to this Agreement shall be performed to the reasonable satisfaction of the COUNTY and in accordance with all applicable Federal, State and local laws, ordinances, rules and regulations. CONSULTANT shall not receive payment for work found by the COUNTY to be unsatisfactory, or performed in violation of Federal, State or local laws, ordinances, rules or regulations.
2. Notwithstanding any provision of this Agreement to the contrary, CONSULTANT shall remain liable to the COUNTY for damages sustained by the COUNTY by virtue of any breach of the contract by CONSULTANT. Upon notice to CONSULTANT of the claimed breach and the amount of the claimed damage, the COUNTY may withhold any payments to CONSULTANT for the purpose of set-off until such time as the exact amount of damages owed to the COUNTY from CONSULTANT is determined. The set-off may be used by the COUNTY to satisfy the amount of damages. If the set-off amount is not sufficient to satisfy the damages, the COUNTY may make a claim for the unsatisfied damages amount. The above remedies shall be in addition to any other right or remedy available to the COUNTY under this Agreement, law, statute, rule, and/or equity. Following notice from the COUNTY of

the claimed breach and damage, CONSULTANT and the COUNTY shall attempt to resolve the dispute in good faith.

SECTION 10. DEFAULT AND CANCELLATION/TERMINATION AND SUBMITTAL OF CONTRACT DOCUMENTS

A. Default and Cancellation/Termination

1. If CONSULTANT fails to perform any of the provisions of this Agreement or so fails to administer the work as to endanger the performance of the Agreement, it shall be in default. Unless CONSULTANT's default is excused by the COUNTY, or the COUNTY in its sole discretion determines CONSULTANT should be given an opportunity to cure a breach of this Agreement, the COUNTY may upon written notice immediately cancel or terminate this Agreement in its entirety. Additionally, failure to comply with the terms of this Agreement shall be just cause for the COUNTY to delay payment until CONSULTANT's compliance. In the event of a decision to withhold payment, the COUNTY shall furnish prior written notice to CONSULTANT.
2. Upon cancellation or termination of this Agreement:
 - a. At the discretion of the COUNTY and as specified in writing by the Project Manager, CONSULTANT shall deliver to the Project Manager copies of all writings so specified by the COUNTY and prepared by CONSULTANT in accordance with this Agreement. The term "writings" is defined as:

Handwriting, typewriting, printing, photocopying, photographing, facsimile transmitting, and every other means of recording, including electronic media, any form of communication or representation, including letters, works, pictures, drawings, sounds, or symbols, or combinations thereof.
 - b. The COUNTY shall have full ownership and control of all such writings. CONSULTANT shall have the right to retain copies of the writings. However, it is agreed that CONSULTANT without the prior written consent of the COUNTY shall not use these writings for any purpose or in any manner whatsoever; shall not assign, license, loan, sell, copyright, patent and/or transfer any or all of such writings; and shall not do anything which in the opinion of the COUNTY would affect the COUNTY's ownership and/or control of such writings. Notwithstanding the terms of this section, CONSULTANT shall retain full rights to reuse in the normal course of business its standard details and specifications contained in the writings.
3. The above remedies shall be in addition to any other right or remedy available to the COUNTY under this Agreement, law, statute, rule, and/or equity.
4. The COUNTY's failure to insist upon strict performance of any provision or to exercise any right under this Agreement shall not be deemed a relinquishment or waiver of the same, unless consented to in writing. Such consent shall not constitute a general waiver or relinquishment throughout the entire term of the Agreement.

5. This Agreement may be canceled/terminated with or without cause by either party upon thirty (30) day written notice.
6. If this Agreement expires or is cancelled or terminated, with or without cause, by either party, at any time, CONSULTANT shall not be entitled to any payment, fees or other monies except for payments duly invoiced for then delivered and accepted deliverables/milestones pursuant to the terms expressly set forth herein. In the event CONSULTANT has performed work toward a deliverable that the COUNTY has not accepted at the time of expiration, cancellation or termination, CONSULTANT hereby expressly acknowledges and agrees that CONSULTANT shall be entitled to payment for said work only if it is accepted by the COUNTY, and shall not be entitled to any termination expenses, including lost profits or other costs founded on termination for convenience theories or any other payments, fees, costs or expenses not expressly set forth herein.

B. Submittal of Contract Documents

The originals of all drawings, work sheets, reports, computations, plans, field notes, electronic data and other Project data shall be turned over to the COUNTY as follows:

1. Upon written notice of cancellation of the Agreement.
2. Prior to final settlement of a dispute arising out of this Agreement.
3. Prior to final payment of the ultimate gross amount earned.

Any notice or demand which must be given or made by a party under this Agreement or any statute or ordinance shall be in writing and shall be sent by registered or certified mail. Notices to CONSULTANT shall be sent to its address as set forth in the opening paragraph of this Agreement. Notices to Hennepin County shall be directed to:

County Administrator
A-2300 Government Center
300 South Sixth Street
Minneapolis, Minnesota 55487

with copies to:

Consulting Services Program Manager
Hennepin County Purchasing and Contract Services
A-1730 Government Center
300 South Sixth Street
Minneapolis, Minnesota 55487-0175

Any party hereto may designate a different addressee or address at any time by giving written notice thereof as above provided. Any notice, if mailed, properly addressed, postage prepaid, registered or certified mail, shall be deemed dispatched on the registered date or that stamped on the certified mail receipt and shall be deemed received within the second business day thereafter or when it is actually received, whichever is sooner.

SECTION 11. DATA PRACTICES

CONSULTANT, its officers, agents, owners, partners, employees, volunteers and subconsultants shall abide by the provisions of the Minnesota Government Data Practices Act, Minnesota Statutes, Chapter 13 (MGDPA) and all other applicable state and federal laws, rules, regulations and orders relating to data privacy or confidentiality, which may include the Health Insurance Portability and Accountability Act of 1996 (HIPAA) and/or the Health Information Technology for Economic and Clinical Health Act (HITECH), adopted as part of the American Recovery and Reinvestment Act of 2009. CONSULTANT acknowledges and agrees that classification of data as trade secret data will be determined pursuant to applicable law and, accordingly, merely labeling data as “trade secret” does not necessarily make it so. If CONSULTANT creates, collects, receives, stores, uses, maintains or disseminates data because it performs functions of the COUNTY pursuant to this Agreement, then CONSULTANT must comply with the requirements of the MGDPA as if it were a government entity, and may be held liable under the MGDPA for noncompliance. CONSULTANT agrees to promptly notify the COUNTY if it becomes aware of any potential claims, or facts giving rise to such claims, under the MGDPA. The terms of this section shall survive the expiration, cancellation or termination of this Agreement.

SECTION 12. NON-DISCRIMINATION

In accordance with the COUNTY’s policies against discrimination, CONSULTANT agrees that it shall not exclude any person from full employment rights nor prohibit participation in or the benefits of, any program, service or activity on the grounds of race, color, creed, religion, age, sex, disability, marital status, sexual orientation, public assistance status, or national origin. No person who is protected by applicable Federal or State laws against discrimination shall be subjected to discrimination.

SECTION 13. AFFIRMATIVE ACTION

- A. Exemptions: CONSULTANT may be granted an exemption from the requirements of this Section for one of the following reasons:
- (1) Contract is for emergency or life safety-related purchases;
 - (2) CONSULTANT has no facilities and has no more than one employee operating within the geographic boundaries of Hennepin County;
 - (3) CONSULTANT had an average of forty (40) or fewer full-time/benefit-earning employees during the twelve (12) months preceding the submission of the bid, request for proposal or execution of this Agreement; or
 - (4) Pursuant to Hennepin County Board policy, the County Administrator or his/her designee granted an exemption.
- B. Requirements. In accordance with Hennepin County Board Resolution and subject to the applicable exemptions, if any, listed above, if this Agreement is for a sum over \$100,000 or is amended to exceed \$100,000, then CONSULTANT shall abide by the COUNTY’s Affirmative Action requirements for COUNTY contractors. Those

requirements, for purposes of this Agreement, are consistent with those imposed for state contractors pursuant to Minnesota Statutes, sections 363A.36 to .37 and Minnesota Rules, parts 5000.3200 to 5000.3600.

- C. Compliance; Remedies: CONSULTANT shall demonstrate compliance by submitting and maintaining a workforce certificate from the Minnesota Department of Human Rights (MDHR), unless the COUNTY provides for alternative certification. CONSULTANT shall remain in compliance with all applicable requirements through the term of this Agreement. CONSULTANT shall also provide all compliance documentation requested by the MDHR or by the COUNTY, and shall cooperate with all compliance activities, including but not limited to site visits. If CONSULTANT fails to demonstrate good faith efforts to correct any identified Affirmative Action deficiencies or fails to submit requested reports or information required by the COUNTY or the MDHR, or has engaged in discriminatory practices, the COUNTY may consider this a violation of this Agreement and may exercise any remedies available to it in law or in equity, including, but not limited to, cancellation or termination of this Agreement.

SECTION 14. SMALL BUSINESS ENTERPRISE PROGRAM

The COUNTY is committed to utilization of Emergent Small Business Enterprises (ESBEs) and Small Business Enterprises (SBEs) in this program—both of which include businesses owned by people of color and women. The COUNTY recognizes the SBE certification and ESBE designated of small businesses certified by the Central Certification (CERT) Program.

The COUNTY may include a sub-consulting goal for small businesses owned by people of color (SMBEs) or SBEs within the solicitation for a Project. Goals are based on several factors, including the size of the project, the nature of the work involved, and the relative availability of targeted firms within the applicable professional discipline(s) of the work. CONSULTANT must either commit to goal attainment or demonstrate good faith efforts to meet the established goal.

SECTION 15. INSPECTION OF WORK AND DOCUMENTS

Duly authorized representatives of the COUNTY shall have the right to inspect the work and documents of CONSULTANT whenever COUNTY deems such inspection necessary.

SECTION 16. SUCCESSORS, NON-ASSIGNMENT AND SUBCONTRACTING

CONSULTANT binds itself, its partners, successors, assigns and legal representatives to the COUNTY in respect to all covenants, agreements and obligations contained in the contract documents. All work and services described in the proposal submitted by CONSULTANT to the Project Manager shall be the primary responsibility of CONSULTANT and CONSULTANT shall not assign, subcontract, transfer, or pledge this Agreement and/or the services to be performed hereunder, whether in whole or in part, nor assign any monies due or to become due to it hereunder to any subcontractors, without the prior written consent of the COUNTY. This written consent shall in no way relieve CONSULTANT from its

primary responsibility for performance of the work, except as noted in the Scope of Work upon which the Consultant Services Authorizes was issued.

Permission to subcontract, however, shall under no circumstances relieve CONSULTANT of its liabilities and obligations under the Agreement. Further, CONSULTANT shall be fully responsible for the acts, omissions, and failure of its subcontractors in the performance of the work authorized by a Consulting Services Authorization, and of person(s) directly or indirectly employed by subcontractors. Contracts between CONSULTANT and each subcontractor shall require that the subcontractor's services be performed in accordance with the terms and conditions herein specified. A consent to assign shall be accomplished by execution of a form prepared by the COUNTY and signed by CONSULTANT, the assignee and the COUNTY. Any approved subcontractors hired by CONSULTANT shall be independent contractors for the purposes of completing the work provided for in this Agreement.

SECTION 17. BROKERAGE FEE

CONSULTANT warrants that it has not employed or retained any company or person, other than a bona fide employee working solely for CONSULTANT, to solicit or secure this contract, and that it has not paid or agreed to pay any company or person, other than a bona fide employee working for CONSULTANT, any fee, commission, percentage, brokerage fee, gifts, or any other consideration, contingent upon or resulting from the award or making of the Agreement. For breach or violation of this warranty the COUNTY shall have the right to immediately cancel this Agreement without liability or, in its discretion, to deduct from the contract price or consideration, or otherwise recover, the full amount of such fee, commission, percentage, brokerage fee, gift, or contingent fee.

SECTION 18. INDEPENDENT CONTRACTOR

CONSULTANT shall select the means, method, and manner of performing the services. Nothing is intended or should be construed as creating or establishing the relationship of a partnership or a joint venture between the parties or as constituting CONSULTANT as the agent, representative, or employee of the COUNTY for any purpose. CONSULTANT is and shall remain an independent contractor for all services performed under this Agreement. CONSULTANT shall secure at its own expense all personnel required in performing services under this Agreement. Any personnel of CONSULTANT or other persons while engaged in the performance of any work or services required by CONSULTANT will have no contractual relationship with the COUNTY and will not be considered employees of the COUNTY. The COUNTY shall not be responsible for any claims that arise out of employment or alleged employment under the Minnesota Unemployment Insurance Law or the Workers' Compensation Act of the State of Minnesota on behalf of any personnel, including, without limitation, claims of discrimination against CONSULTANT, its officers, agents, contractors, or employees. Such personnel or other persons shall neither require nor be entitled to any compensation, rights, or benefits of any kind from the COUNTY, including, without limitation, tenure rights, medical and hospital care, sick and vacation leave, workers' compensation, unemployment compensation, disability, severance pay, and retirement benefits.

SECTION 19. INDEMNIFICATION AND INSURANCE

A. INDEMNIFICATION

CONSULTANT agrees to defend, indemnify, and hold harmless the COUNTY, its officials, officers, agents, volunteers and employees from any liability, claims, causes of action, judgments, damages, losses, costs, or expenses, including reasonable attorney’s fees, resulting directly or indirectly from any act or omission of CONSULTANT, a subconsultant, anyone directly or indirectly employed by them, and/or anyone for whose acts and/or omissions they may be liable in the performance of the services required by this Agreement, and against all loss by reason of the failure of CONSULTANT to perform any obligation under this Agreement. For clarification and not limitation, this obligation to defend, indemnify and hold harmless includes but is not limited to any liability, claims or actions resulting directly or indirectly from alleged infringement of any copyright or any property right of another, the employment or alleged employment of CONSULTANT personnel, the unlawful disclosure and/or use of protected data, or other noncompliance with the requirements of the Data Practices provisions set forth in Section 11 hereof. Nothing herein is intended to impose an obligation on CONSULTANT that is void and unenforceable under Minnesota Statutes Section 604.21. Nothing herein is intended to constitute a waiver of any rights of the COUNTY to indemnity or contribution under Minnesota law.

B. INSURANCE

1. With respect to the services provided pursuant to this Agreement, CONSULTANT shall, at its sole expense, procure and maintain insurance of the types, and in the form and amounts described below from insurer(s) authorized to transact business in the state where services or operations will be performed by CONSULTANT. Such insurance and required coverage shall be in forms acceptable to the COUNTY. The insurance requirements described below shall be maintained uninterrupted for the duration of this Agreement and beyond such term when so required, and shall cover CONSULTANT, and others for whom and/or to whom CONSULTANT may be liable, for liabilities in connection with work performed for or on behalf of the COUNTY, its agents, representatives, employees or contractors. CONSULTANT is required to have and keep in force the following minimum insurance coverages or CONSULTANT’s actual insurance limits for primary coverage and excess liability or umbrella policy limits, whichever is greater:

	REQUIRED INSURANCE COVERAGES	MINIMUM
(1)	<p><u>Commercial General Liability (CGL)</u></p> <p style="text-align: right;">General Aggregate</p> <p style="text-align: right;">Products—Completed Operations Aggregate</p> <p style="text-align: right;">Personal and Advertising Injury</p> <p style="text-align: right;">Each Occurrence—Combined Bodily Injury and Property Damage</p> <p>Coverage shall be on an occurrence basis and include contractual liability coverage. Coverage shall be written on the most current ISO (Insurance Services Office, Inc.) CGL form or its equivalent.</p>	<p>\$2,000,000</p> <p>\$2,000,000</p> <p>\$1,500,000</p> <p>\$1,500,000</p>

(2)	<p style="text-align: center;"><u>Workers' Compensation and Employer's Liability</u></p> <p style="text-align: right;">Workers' Compensation Employer's Liability: Bodily injury by accident—Each Accident Employer's Liability: Bodily injury by Disease—Policy Limit Employer's Liability: Bodily injury by Disease—Each Employee</p> <p>If CONSULTANT is based outside the state of Minnesota, coverage must comply with Minnesota law. If CONSULTANT is a sole proprietor, it is exempted from the above Workers' Compensation requirements to the extent provided by Minnesota law. In the event that CONSULTANT should hire employees or subcontract this work, CONSULTANT shall obtain the required insurance.</p>	<p>Statutory \$500,000 \$500,000 \$500,000</p>
(3)	<p style="text-align: center;"><u>Professional Liability (PL/E&O)</u></p> <p style="text-align: right;">Per Claim Aggregate</p> <p>The professional liability insurance must be maintained continuously for a period of three (3) years after final acceptance of services or the expiration, cancellation or termination of this Agreement, whichever is later. Coverage shall include liability arising from the errors, omissions or acts of CONSULTANT or any entity for which CONSULTANT is legally responsible in the providing of services under the Agreement. Throughout the term of the Agreement, the PL/E&O policy shall include full prior acts coverage.</p>	<p>\$1,500,000 \$2,000,000</p>
(4)	<p style="text-align: center;"><u>Automobile Liability</u></p> <p>CONSULTANT shall maintain automobile liability and, if necessary, commercial umbrella insurance. Such insurance shall cover liability for bodily injury and property damage arising from the use or operation of any auto, including those owned, hired or otherwise operated or used by or on behalf of CONSULTANT.</p>	<p>\$500,000</p>

2. An umbrella or excess policy is an acceptable method to provide the required commercial general insurance coverage.

Coverage shall not include any exclusion or other limitations related to:

- (1) Scope of services;
- (2) Delays in project completion and cost overruns;
- (3) Persons or entities authorized to notify the carrier of a claim or potential claim; or
- (4) Mold, fungus, asbestos, pollutants or other hazardous substances.

The above establishes minimum insurance requirements. It is the sole responsibility of CONSULTANT to determine the need for and to procure additional insurance which may be needed in connection with this Agreement. Upon written request, CONSULTANT shall promptly submit copies of insurance policies to the COUNTY.

CONSULTANT shall not commence work until it has obtained required insurance and filed with the COUNTY a properly executed Certificate of Insurance establishing compliance. The certificate(s) must name Hennepin County as the certificate holder,

and as an additional insured for the commercial general liability and the automobile liability coverages required herein. A self-insured retention (SIR) is not acceptable, unless expressly agreed to in writing by the COUNTY. The funding of deductibles and self-insured retentions maintained by CONSULTANT, if allowed by the COUNTY, shall be the sole responsibility of CONSULTANT. If the certificate form contains a certificate holder notification provision, the certificate shall state that the insurer will endeavor to mail to the COUNTY thirty (30) day prior written notice in the event of cancellation/termination of any described policies; however, in the event the insurance carrier will not issue or endorse its policy(s) to comply with the notice provision in the preceding clause, CONSULTANT shall assume such notice obligations. If CONSULTANT receives notice of cancellation/termination from an insurer, CONSULTANT shall fax or email a copy of the notice to the COUNTY within two (2) business days.

CONSULTANT shall furnish to the COUNTY updated certificates during the term of this Agreement as insurance policies expire. If CONSULTANT fails to furnish proof of insurance coverages, the COUNTY may withhold payments and/or pursue any other right or remedy allowed under contract, law, equity, and/or statute.

CONSULTANT's required insurance shall be primary insurance and any insurance or self-insurance maintained by the COUNTY shall be in excess of and non-contributory with CONSULTANT'S insurance. CONSULTANT waives all rights against the COUNTY, its officials, officers, agents, volunteers, and employees for recovery of damages to the extent that damages are covered by insurance of CONSULTANT. If necessary, CONSULTANT agrees to endorse the required insurance policies to permit waivers of subrogation in favor of the COUNTY.

3. Duty to Notify. CONSULTANT shall promptly notify the COUNTY of any claim, action, cause of action or litigation brought against CONSULTANT, its employees, officers, agents or subcontractors, which arises out of the services contained in this Agreement. CONSULTANT shall also notify the COUNTY whenever CONSULTANT has a reasonable basis for believing that CONSULTANT and/or its employees, officers, agents or subconsultants, and/or the COUNTY, might become the subject of a claim, action, cause of action, criminal arrest, criminal charge or litigation arising out of and/or related to the services contained in this Agreement. Failure to provide the notices required by this section is a material violation of the terms and conditions of this Agreement.

SECTION 20. OWNERSHIP OF DOCUMENTS

Original drawings, specifications, and other deliverables, including electronic media are the property of the COUNTY, and CONSULTANT may not use said deliverables for any purpose not relating to the Project without the COUNTY's consent. The COUNTY shall be furnished with such reproductions as the COUNTY may reasonably require. Upon completion of the work, CONSULTANT will revise any drawings to reflect changes made during construction in accordance with Section 6.G and will promptly furnish the COUNTY with documentation as required under this Agreement. Project information shall be furnished at any other time requested by the COUNTY. All such CAD electronic data files and reproductions are the property of the COUNTY which may use them without CONSULTANT's permission for any purpose relating to the Project, including, but not limited to, additions, or modifications to, or

completion of the Project or submission or distribution of documents by the COUNTY to meet official regulatory requirements. Notwithstanding the terms of this section, CONSULTANT shall retain full rights to use any standard details that are incorporated into the deliverables produced by CONSULTANT in connection with the Project. Regardless of any transfer of ownership or copyright rights granted to the COUNTY pursuant to the terms of this Agreement, CONSULTANT shall not be restricted or prohibited from future use of any such standard details or reuse of component information contained in the drawings and specifications in the normal course of business.

SECTION 21. FURNISHING OF INFORMATION TO THE COUNTY

At the request of the COUNTY, CONSULTANT shall furnish to the COUNTY during the progress of the work such designs or other information or data in such detail as may be required to enable the COUNTY to carry out or to proceed with related phases of the Project not covered by the Agreement, or which may be necessary to enable the COUNTY to furnish information to CONSULTANT upon which to proceed with further work. The information shall be furnished in the manner specified by the COUNTY that may include, but not be limited to, reproducible plan sheets and electronic files compatible with the COUNTY's computer system.

SECTION 22. RECORDS – AVAILABILITY/ACCESS

Subject to the requirements of Minnesota Statutes Section 16C.05, Subd. 5, CONSULTANT agrees that the COUNTY, the State Auditor, or any of their authorized representatives, at any time during normal business hours, and as often as they may reasonably deem necessary, shall have access to and the right to examine, audit, excerpt, and transcribe any books, documents, papers, records, etc., which are pertinent to the accounting practices and procedures of CONSULTANT and involve transactions relating to this Agreement. CONSULTANT shall maintain these materials and allow access during the period of this Agreement and for six (6) years after its expiration, cancellation or termination.

SECTION 23. CONTINUATION OF OBLIGATION

It is expressly understood and agreed that the obligations of CONSULTANT under this Agreement shall survive the completion of performance and expiration, cancellation, or termination of this Agreement.

SECTION 24. MERGER AND MODIFICATION

- A. It is understood and agreed that the entire Agreement between the parties is contained herein and that this Agreement supersedes all oral agreements and negotiations between the parties relating to the subject matter. All items that are referenced or that are attached are incorporated and made a part of this Agreement. However, to the extent that CONSULTANT includes any terms and conditions in its proposal or in any other writing that are inconsistent with the terms and conditions in this Agreement, including but not limited to terms relating to liability or indemnity, the terms and conditions in this Agreement shall govern.

- B. Any alterations, variations, modifications, or waivers of provisions of this Agreement shall only be valid when they have been reduced to writing as an amendment to this Agreement signed by the parties. Notwithstanding the foregoing, as provided in Section 6.C, the COUNTY may modify Supplementary Technical Requirements set forth in Exhibits F-1, F-2 and F-3, by providing notice to CONSULTANT of such modifications, at which time such modifications will become effective. In addition, the COUNTY may modify other terms and conditions of this Agreement that do not impose any additional responsibility or cost or liability on CONSULTANT and do not impair any of the rights of CONSULTANT herein, by providing notice to CONSULTANT of such modifications, at which time such modifications will become effective.
- C. CONSULTANT and/or the COUNTY are each bound by its own electronic signature(s) on this Agreement, and each agrees and accepts the electronic signature of the other party.

SECTION 25. PAPER RECYCLING

The COUNTY encourages CONSULTANT to develop and implement an office paper and newsprint-recycling program.

SECTION 26. USE OF CONTRACT BY OTHER METRO-AREA COUNTIES

Hennepin County is a signatory to a Joint Powers Purchasing Agreement (Agreement No. A131396) (the "JPA") formed with the following Minnesota counties: Anoka, Carver, Dakota, Olmsted, Ramsey, Scott and Washington. Pursuant to the JPA, such counties may purchase the same or substantially similar services as provided hereunder from CONSULTANT through a separate agreement between such county and CONSULTANT. COUNTY shall have no obligation, liability or responsibility for any services purchased by such other county under its separate contract with CONSULTANT.

SECTION 27. MISCELLANEOUS

The matters set forth in the "whereas" clauses at the beginning of this Agreement are incorporated into and made a part hereof by this reference.

To the extent of any inconsistencies between the Exhibits and the Sections herein, the Sections herein shall govern.

The Laws of the State of Minnesota shall govern all questions and interpretations concerning the validity and construction of this Agreement and the legal relations between the herein parties and performance under it. The appropriate venue and jurisdiction for any litigation hereunder will be those courts located within the County of Hennepin, State of Minnesota. Litigation, however, in the federal courts involving the herein parties will be in the appropriate federal court within the State of Minnesota. If any provisions of this Agreement are held invalid, illegal or unenforceable, the remaining provisions will not be affected.

CONSULTANT certifies that it is not prohibited from doing business with either the federal government or the State of Minnesota as a result of debarment or suspension proceedings. CONSULTANT shall comply with all applicable federal, state and local statutes, regulations, rules and ordinances in force or hereafter enacted. If the source or partial source of funds for payment of services under this Agreement is federal, state or other grant monies, CONSULTANT shall comply with all applicable conditions and requirements of any such funding.

SECTION 28. LIST OF EXHIBITS AND APPENDICES

- Exhibit A: Consulting Services Program Application
- Exhibit B: Consulting Services Authorization
- Exhibit C: Consulting Services Authorization Amendment
- Exhibit D-1: Consulting Services Solicitation Request – Cost-Based Version
- Exhibit D-2: Consulting Services Solicitation Request – QBS Version
- Exhibit E: Consultant Invoice Example

Supplementary Technical Requirements

- Exhibit F-1: Transportation Computer-Aided Design Drafting (CAD) Standards
- Exhibit F-2: Computer-Aided Drafting (CAD) Protocol for Facility Projects
- Exhibit F-3: Planning, Design and Construction Standards for Architectural Services

COUNTY ADMINISTRATOR APPROVAL

Reviewed for COUNTY by
the County Attorney's Office:

COUNTY OF HENNEPIN
STATE OF MINNESOTA

{ {Sig_es_:signer3:signature} }
{ {userstamp3_es_:signer3:stamp} }

By:

{ {Sig_es_:signer5:signature} }
{ {userstamp5_es_:signer5:stamp} }

Reviewed for COUNTY by:

{ {Sig_es_:signer4:signature} }
{ {userstamp4_es_:signer4:stamp} }

Document Assembled by:

{ {Sig_es_:signer1:signature} }
{ {userstamp1_es_:signer1:stamp} }

{ {Exh_es_:signer1:attachment:label("Attachments")} }

CONSULTANT

CONSULTANT warrants that the person who executed this Agreement is authorized to do so on behalf of CONSULTANT as required by applicable articles, bylaws, resolutions or ordinances.*

By:

{ {Sig_es_:signer2:signature} }
{ {userstamp2_es_:signer2:stamp} }
{ { ttl_es_:signer2:title} }

*CONSULTANT represents and warrants that it has submitted to COUNTY all applicable documentation (articles, bylaws, resolutions or ordinances) that confirms the signatory's delegation of authority. Documentation is not required for a sole proprietorship.



Hennepin County
 Purchasing & Contract Services
Hennepin County Government Center
 300 South 6th Street
 Minneapolis, MN 55487

CSP Application (12/04/2019)

**HENNEPIN COUNTY
 CONSULTING SERVICES PROGRAM
 APPLICATION FORM**

Work type selection

<p>Architecture, facility engineering, and specialties</p> <p>Architecture</p> <ul style="list-style-type: none"> <input type="checkbox"/> Corrections facilities <input type="checkbox"/> Historic preservation <input type="checkbox"/> Judicial facilities <input type="checkbox"/> Library facilities <input type="checkbox"/> Medical facilities <input type="checkbox"/> Office facilities <input type="checkbox"/> Public works maintenance shops/garages <input type="checkbox"/> Residential facilities <input type="checkbox"/> Transit facilities <p>Facility engineering</p> <ul style="list-style-type: none"> <input type="checkbox"/> Civil engineering <input type="checkbox"/> Commissioning/recommissioning <input type="checkbox"/> Mechanical engineering <input type="checkbox"/> Electrical engineering <input type="checkbox"/> Structural engineering <p>Facility services specialties</p> <ul style="list-style-type: none"> <input type="checkbox"/> Building forensics <input type="checkbox"/> Computer aided facilities management (CAFM) <input type="checkbox"/> Construction management <input type="checkbox"/> Cost estimating <input type="checkbox"/> Elevator/escalator <input type="checkbox"/> Facility audits - accessibility audits <input type="checkbox"/> Facility preservation <input type="checkbox"/> Fiber optic engineering and planning <input type="checkbox"/> Interior design and system furniture <input type="checkbox"/> Indoor air quality - industrial hygiene <input type="checkbox"/> Move coordination <input type="checkbox"/> Roofing <input type="checkbox"/> Safety training and consulting <input type="checkbox"/> Security systems <input type="checkbox"/> Signage 	<p>Asbestos and solid waste</p> <ul style="list-style-type: none"> <input type="checkbox"/> Asbestos, lead paint, and regulated building materials <input type="checkbox"/> Solid waste and recycling services <p>Community development</p> <ul style="list-style-type: none"> <input type="checkbox"/> Land use planning and urban design <input type="checkbox"/> Market analysis and studies <p>Community engagement</p> <ul style="list-style-type: none"> <input type="checkbox"/> Community engagement and public involvement <input type="checkbox"/> Graphic design, rendering, mapping, and imagery <p>Cultural resources</p> <ul style="list-style-type: none"> <input type="checkbox"/> Archaeological studies <input type="checkbox"/> Architecture history studies <input type="checkbox"/> Geomorphology <p>Energy</p> <ul style="list-style-type: none"> <input type="checkbox"/> Energy contracting and marketing <input type="checkbox"/> Power plant/district energy engineering <p>Environment</p> <ul style="list-style-type: none"> <input type="checkbox"/> Air quality modeling and permitting <input type="checkbox"/> Environmental documentation <input type="checkbox"/> Environmental property assessment and clean-up <input type="checkbox"/> Natural resources <input type="checkbox"/> Noise analysis and abatement <p>Landscape architecture</p> <ul style="list-style-type: none"> <input type="checkbox"/> Landscape architecture <p>Materials testing</p> <ul style="list-style-type: none"> <input type="checkbox"/> Geotechnical studies, soils analysis, and recommendations <input type="checkbox"/> Ground penetrating radar <input type="checkbox"/> Materials testing and drilling <input type="checkbox"/> Pile load testing - MnDOT approval required <input type="checkbox"/> Vibration analysis and monitoring 	<p>Right of way assistance</p> <ul style="list-style-type: none"> <input type="checkbox"/> Relocation assistance <input type="checkbox"/> Right of way appraisals <input type="checkbox"/> Title services <p>Surveying and mapping</p> <ul style="list-style-type: none"> <input type="checkbox"/> Construction surveying <input type="checkbox"/> Land surveying <input type="checkbox"/> Photogrammetric mapping and aerial imagery <input type="checkbox"/> Subsurface utility engineering <p>Transportation</p> <p>Bridge and structure</p> <ul style="list-style-type: none"> <input type="checkbox"/> Bridge and structure design and structure metals inspection - MnDOT approval required <p>Construction inspection and contract administration</p> <ul style="list-style-type: none"> <input type="checkbox"/> Construction contract administration and management <input type="checkbox"/> Construction inspection bridge construction <input type="checkbox"/> Construction inspection grading base bituminous and concrete <p>Hydraulics and hydrology</p> <ul style="list-style-type: none"> <input type="checkbox"/> Water resources services <p>Pedestrian and bicycle</p> <ul style="list-style-type: none"> <input type="checkbox"/> Pedestrian and bicycle planning, engineering, and promotion <p>Roadway</p> <ul style="list-style-type: none"> <input type="checkbox"/> Major roadway <input type="checkbox"/> Roadway <input type="checkbox"/> Roundabouts <input type="checkbox"/> Value engineering <p>Traffic</p> <ul style="list-style-type: none"> <input type="checkbox"/> Roadway lighting design <input type="checkbox"/> Temporary traffic control plan design <input type="checkbox"/> Traffic engineering special studies <input type="checkbox"/> Traffic signal design and operation <p>Transit</p> <ul style="list-style-type: none"> <input type="checkbox"/> Transit planning, engineering, and construction management
--	---	--



CONSULTANT SERVICES AUTHORIZATION

Hennepin County

PURCHASE ORDER NUMBER: *[This number is provided to the Project Manager when the CSA Transmittal is approved.]*

To: [Consultant]

From: [Project Manager Name, Division, Phone Number, and e-mail]

Date:

Project Name:

Project No.:

Authorization Name: *Name of the phase, or task*

Thank you for your recent proposal on the above referenced project. You have been selected to perform the work based on your proposal submitted on _____. You are now authorized to begin work on this project, per the final negotiated Scope of Services, see attached.

The maximum amount of services authorized for this project shall not exceed \$_____ with all work completed by_____.

The compensation for services provided under this authorization shall be based on the actual hours worked times the rate schedule included in your proposal. These rates will remain in effect throughout the term of this Authorization.

Invoices

Please submit invoices and back up information to the following central PO Box:

Hennepin County Accounts Payable
PO Box 1388
Minneapolis, MN 55440-1388

You may also send it via email to obf.internet@co.hennepin.mn.us. Please also forward an electronic copy to my attention.

Invoices shall include the date of the invoice, the invoice number, the Consultants' taxpayer identification number, the name and address of the project manager, the project name and number, and the Consultant's contract number and Consultant Service Authorization Purchase Order number (see above).



Consulting Services Authorization Amendment
Amendment No _____

Purchase Order No.:

Master agreement No.:

To:

From:

Date:

Project Name:

Project No:

Authorization Name:

By this Amendment the County authorizes the modification to the scope of services document dated **[Enter Date]** and said modifications to the scope of services which are described in the attached Modified Scope of Services document, which is incorporated hereto by this reference.



CONSULTANT SERVICES SOLICITATION REQUEST

Hennepin County

Date:

To: Consultant

From: Project Manager,
Hennepin County

Project Name:

Project Number:

Thank you for participating in the Hennepin County Consulting Services Program. We are requesting a proposal regarding the above referenced project.

Project Overview:

- Give a brief overview of the project including the goals of the project
- Describe any existing information that will be provided to the consultant
- List the due date and time for the proposals

Scope of Work:

Give a detailed description of the work to be accomplished by the consultant.

- If this is a phased project describe each phase.
- Include a detailed description of the anticipated project deliverables.
- Note if a specific method or standards are to be followed in completing the project.

Project Schedule:

- List the anticipated start and end date of the project.
- Note any mission critical dates associated with the project.

Response Content:

Project Team: (Include professional credentials, if applicable)

1. Project Manager - Name, Contact Information, Relevant previous project experience
2. Critical Team Members – Name, Relevant previous project experience
3. Other Team Member – Identify by name and or position.
4. If the project team includes Sub-Consultants identify the key personnel of that firm, the sub consultant's responsibilities/tasks and the subconsultant's fees as a percentage of the overall project fee.

Detailed Work Plan:

- Describe your approach and methodology in completing the project.
- Identify the major tasks/phases of the project in sequential order
- Describe any assumptions upon which your proposal is based.

Budget/Cost Proposal

- List estimated hours assigned and hourly rate for ALL personnel identified on the Project Team.

- List any other anticipated project expenses, including reimbursable items.
- Clearly identify the total cost of the proposal including fees and expenses.

Proposal length

Limit your proposal to **XX** pages, excluding cover letter. Additional pages will not be reviewed or evaluated.

Other

- Do not include general marketing materials or other information not directly related to this request.
- Clearly identify the level of participation, services, or information to be provide by the county
- Billing rates contained in the proposal shall be valid for the entire length of the project.
- Do not include terms and conditions that differ from those within the Master Agreement.
- Submit any questions related to this solicitation directly to the project manager in writing via email by [Date & Time].
- Hennepin County reserves the right to not proceed with this the described project if it determines that it is in its best interest.
- All costs related to preparing the proposal shall be borne by the consultant.
- Proposals shall be submitted via email attachment in PDF Format sent to the Hennepin County Project Manager at [Provide email address].
- Response to this solicitation must be received no later than **[Date at Time]** Central Time Zone.

Proposal Evaluation

The following factors will be considered in the evaluation of proposals and are listed in the order of importance.

[Prioritize the order of the following and modify if necessary]

- A. Project Understanding and approach
- B. Work Plan
- C. Cost
- D. Experience of project team
- E. Value Added items

We do not anticipate an interview of the consultants for this project, however we reserve the right to include an interview as part of the consultant selection process.

Hennepin County anticipates that the consultant selection will be completed by **[DATE]**.

We look forward to receiving your proposal.

Sincerely,

Project Manager



CONSULTANT SERVICES SOLICITATION REQUEST for a Qualifications-Based Selection (QBS)

Hennepin County Public Works

Date:

To:

[Firm]

From: [Project Manager]

Project Manager, [Department]

Project Name: [Project Name]

Project Number: [Project Number(HC)]

Thank you for participating in the Hennepin County Consulting Services Program. We are requesting a proposal regarding the above referenced project.

Project Overview:

- *Briefly describe the project rationale, including background information.*
- *Describe any existing information that will be provided to the consultant*
- *List the due date for the proposals*

Scope of Work:

Give a detailed description of the work to be accomplished by the consultant.

- *If this is a phased project describe each phase.*
- *Include a detailed description of the anticipated project deliverables.*
- *Note if a specific method or standards are to be followed in completing the project.*

Project Schedule:

- *List the anticipated start and end date of the project.*
- *Note any mission critical dates associated with the project.*

Personnel:

Our solicitation is based upon the availability and inclusion of the following personnel on the project team:

- *List the names of the REQUIRED team members for the project.*

Response Content:

Project Team:

1. Project Manager - Name, Contact Information, Relevant previous project experience
2. Critical Team Members – Name, Relevant previous project experience
3. Other Team Member – Identify by name and or position.
4. If the project team includes Sub-Consultants identify the key personnel of that firm, the sub consultant's responsibilities/tasks and the subconsultant's fees as a percentage of the overall project fee.

Detailed Work Plan:

- Describe your approach and methodology in completing the project.
- Identify the major tasks/phases of the project in sequential order
- Describe any assumptions upon which your proposal is based.

Budget/Cost Proposal:

DO NOT INCLUDE A COST WITHIN YOUR PROPOSAL. THE PROJECT COST WILL BE NEGOTIATED WITH THE HIGHEST RANKED PROPOSER.

Proposal length

Limit your proposal to **XX** pages, excluding cover letter. Additional pages will not be reviewed or evaluated.

Other

- Do not include general marketing materials or other information not directly related to this request.
- Clearly identify the level of participation, services, or information to be provide by the county
- Terms and conditions contained in the proposal shall be valid for the entire length of the project.
- Submit any questions related to this solicitation directly to the project manager in writing via email.
- Hennepin County reserves the right to not proceed with this the described project if it determines that it is in its best interest.
- All costs related to preparing the proposal shall be borne by the consultant.

Proposal Submittals

- Proposals shall be submitted via email attachment in PDF Format sent to the Hennepin County Project Manager.
- Response to this solicitation must be received no later than **Date at Time** Central Time Zone.

Proposal Evaluation

The following factors will be considered in the evaluation of proposals and are listed in the order of importance.

Prioritize the order of the following and modify if necessary

- A. Project Understanding and approach
- B. Work Plan
- C. Experience of project team
- D. Value Added items

We do not anticipate an interview of the consultants for this project, however we reserve the right to include an interview as part of the consultant selection process.

Hennepin County anticipates that the consultant selection will be completed by **DATE**.

We look forward to receiving your proposal.

Sincerely

[Project Manager]

Project Manager

CONSULTANT INVOICE EXAMPLE

CONSULTANT LETTERHEAD

Invoice Date: January 1, 2006

Invoice No.: 06-7004-1

EIN 40-1234567

(HC Project Manager Name)
 Hennepin County (Department)
 Hennepin County (Facility) Street
 Address
 City, State, ZIP

Project: (HC Project Name)
 HC Project No. 3XXXXXX
 HC Contract No. A0XXXX, Authorization No. XXXXXX
 Hourly to a maximum of \$XX,XXX.XX, including reimbursable expenses

Professional Services – Invoice Period December 1-31, 20XX

<u>Name</u>	<u>Classification</u>	<u>Billable</u>		<u>Amount</u>
		<u>Hours</u>	<u>Rate</u>	
(Firm Name)				
Robert Jones	Principal	00	\$000	\$000.00
Marilyn Smith	Drafter	00	\$000	\$000.00
Mary Smythe	Clerical	00	\$000	\$000.00
			SUBTOTAL	\$000.00

(if applicable):

<u>(Subconsultant Name)(Invoice Date)Attached</u>				
Curt Thompson	Design Engineer	00	\$000	\$000.00
Bill Nelson	Drafter	00	\$000	\$000.00
			SUBTOTAL	\$000.00

TOTAL HOURLY \$000.00

(if applicable):

Reimbursable Expenses:

Printing/Reproduction (Company Name)	\$000.00
Copies	\$000.00
Postage	\$000.00
Courier Service	<u>\$000.00</u>
	SUBTOTAL
	\$000.00

TOTAL AMOUNT DUE THIS INVOICE \$000.00

CONSULTANT INVOICE EXAMPLE

Page 2 of 2

Invoice Date: January 1, 2006

Invoice No.; 06-7004-1

EIN 47-2573605

Project: (HC Project Name)
 HC Project No. 3XXXXXX
 Contract No. AXXXXX, Authorization No. XXXXXX
 Hourly to a maximum of \$27,000.00, including reimbursable expenses

(if applicable):

Professional Services by Phase	Total Fee	% Complete To Date	Current Invoice	Total To Date
Schematic Design (20%)	\$ 5,000.00	0%	\$00.00	\$00.00
Design Development (15%)	\$ 3,750.00	0%	\$00.00	\$00.00
Construction Documents (40%)	\$10,000.00	0%	\$00.00	\$00.00
Bidding (5%)	\$ 1,250.00	0%	\$00.00	\$00.00
Construction Administration (20%)	\$ 5,000.00	0%	\$00.00	\$00.00
Reimbursable Expenses	\$ 2,000.00	0%	\$00.00	\$00.00
TOTAL PROFESSIONAL SERVICES	\$27,000.00	0%	\$00.00	\$00.00
Less Previously Invoiced Total				\$00.00
TOTAL AMOUNT DUE THIS INVOICE			\$00.00	

HENNEPIN COUNTY PUBLIC WORKS -TRANSPORATION COMPUTER-AIDED DESIGN DRAFTING STANDARDS

All construction plans prepared by a Consultant shall conform to the following standards:

- All plan sheets shall be created and completed in MicroStation .dgn format. Each plan sheet shall be a separate ".dgn file" or model, and all geometrics and line work shall be referenced from .dgn files that are in layout format. The layout format shall be based upon the Minnesota Coordinate System, Southern Zone, North American Datum of 1983 (NAD83)(Non-HARN values). Project coordinates in final form shall be in english units of measure, having northings and eastings of the "Hennepin County Coordinate System" derived by the MnDOT program CONAD83. Property, planimetrics (topography), proposed construction, and utilities shall all reside in separate .dgn files. File structure and level assignments shall be documented. MnDot Level 1 CADD Standards is preferred. All surfaces displayed on the cross sections shall be provided either in .dtm format, or in a Bentley LandXML file. Alignments must be tabulated.
- Engineer's estimates shall include construction item numbers with the proper five-digit extensions (e.g. 2021.501/00010).
- All final plans shall be of direct reading, positive, permanent, reproductions true to scale on 11-inch by 17-inch sheets.
- All drafting on the plans shall be of such size and quality as will permit the making of readable, first class black line prints including clear reproduction of grid lines, symbols and legends. The minimum lettering size for original drafting shall be 0.08 inch in height and 0.065 inch in width. No adhesive backed material shall remain on any plan sheet. Bar scales shall be used throughout the plan.
- Each individual plan sheet shall be certified by a licensed Engineer as required by Minnesota Statues 2000, Chapter 326.12.

The style, form and scale of all drawings, including size, weight and style of lettering shall conform to the above, unless written permission is given to vary said form and style.

HENNEPIN COUNTY
MINNESOTA



Hennepin County CAD Protocol

for all Facility Services Projects

January 2018



HENNEPIN COUNTY CAD and ELECTRONIC INFORMATION PROTOCOL

Purpose of this Protocol

Hennepin County (County and/or Owner) is responsible for providing, maintaining and improving owned and leased facilities. Updated construction records are integral to this mission, so the County developed this process to organize and standardize all electronic project files. The County utilizes a computer-aided facilities management (CAFM) system, so it is essential that electronic project closeout information conforms to software requirements, drawing structure, and submittal intervals defined by this document. Final payment of contract dollars will not be authorized until these Protocol submissions by Consultant and all of its Sub-consultants are satisfactorily received by the County.

Computer Software Requirements

The standard software utilized for all County CAD drawings shall be AutoDesk's AutoCAD Release 2013. Because of potential computer software conflicts, add-on or after-market software programs **may not be used without prior written permission** from the Owner's Representative. All project electronic files shall be submitted in form of 2 dimensional (2D) information. When the Consultant(s) at no extra cost elects to create project documents using 3 dimensional (3D) BIM modelling, Consultant shall transform or flatten 3D information to create 2D drawing files. Consultant shall quality assure that these files adhere to 2D CAD industry standards.

Hennepin County also appreciates the Consultants voluntary no-cost submission of 3D BIM receivables. When 3D model files are provided by the Consultant, Consultant shall comply with the requirements set forth in the County Optional 3D BIM Submittal Appendix. These 3D exports are independent and supplementary to the contractual requirements of this document.

Protocol Terminology

AIA: The American Institute of Architects.

CAD: The design and construction industry acronym for Computer-Aided Drafting.

BIM: The design and construction industry acronym for Building Information Modeling, which refers both to process and digital model(s).

Base Plan Documents: Electronic drawing(s) of the building footprint, walls, and selected building components in a condensed layer format of up to 30 layers (refer Fig. A). The County provides this electronic layer structure for the Consultant's use. While the Consultant(s) may establish unlimited CAD layers for their project set, these condensed Base Plan layers must be created by the Consultant and submitted along with the record documents.

Document Identification: Information will be clearly labeled with the following information, being Hennepin County's:

Formal Project Title	County Project Manager's name
Project Number (not the Consultant's)	Consultant and Sub-Consultants Name(s), and
Contract Number	Project phase along with phase's issue date (Fig. D).
Facility Name and Address	

Construction Documents: This set of project documents shall include all construction-related project information including legal agreements added through to the award of the Contract for Construction. Consultant's use of the current version of the AIA-approved "National CAD Standard" is preferred (<http://www.nationalcadstandard.org>). While establishing the electronic format for construction documents, the Consultant(s) shall be aware of the eventual need to condense drawing layers down to meet Base Plan layering requirements.

Project Record Documents: This complete set shall consist of Construction Documents updated and improved to contain all product substitutions and contract and field modifications accepted and incorporated into the project during construction.

CAD Transmittal Document: Consultant shall provide an electronic document listing all files being submitted along with a description of each file.

Hennepin County Deliverables to the Consultant upon Project Commencement

At the beginning of a project, the Owner's Representative will provide the Consultant with the following materials to aid in the development of the project. Note: Hennepin County provides these materials as a guide to the Consultant and does not guarantee the accuracy of drawing information. The Consultant is responsible for field verification and accuracy of existing conditions.

Deliverable items to Consultant include:

- ◆ This Hennepin County 2D CAD Protocol
- ◆ When available, electronic copies of architectural floor plans (if project is in an existing facility)
- ◆ Electronic template files of County Title blocks, preformatted in the following sheet sizes (inches): 8.5x11, 11x17, 18x24, 24x36, and 30x42. The Base Plan Documents CAD layer set (Fig. A) is included on the 24x36 tab sheet's right-hand edge for the Consultant's use.
- ◆ Instructions for incorporating the CAD template files.
- ◆ These title block and sheet templates are recommended but not mandated for use by the Consultant.
- ◆ Hennepin County Optional 3D BIM Submittal Appendix

Consultant Submittals to Hennepin County during Project Stages

The County requires timely submission of the following documents, prior to the Consultant's request for final Contract payment. Non-conforming Base Plan set(s) and incomplete sets will be returned to the Consultant for corrective actions as directed by the Owner's Representative. We strongly recommend the Consultant closely coordinate these Protocol requirements with all Sub-consultants, whose submissions are often the cause of non-compliance. NOTE: All electronic submittals shall be transferred using data storage medium consisting of a clearly labeled CD, DVD, or flash drive.

1) Consultant acknowledgment to the County – Consultant shall submit written confirmation indicating successful receipt of the aforementioned Hennepin County Deliverables. Confirmation shall include statement of transmission to all Sub-consultants to the Consultant.

2a) Construction Documents – Within two (2) weeks after issuing the Project's Construction Documents, the Consultant shall submit to the County:

- 1 complete and fully bound AutoCAD construction documents DWG export (of each Sheet), and
- 1 corresponding TIFF or PDF copy of drawings (of each Sheet) on a clearly labeled storage medium. (Fig. D).

2b) Construction Base Plan documents – To be sent simultaneously with the above Project Construction documents transmission:

- 1 electronic and bound AutoCAD copy on a clearly labeled storage medium. (Fig. D)

3a) Project Record documents - Within ten (10) weeks of the date of Owner's final payment to the General Contractor, the Consultant shall submit to the County:

- 1 complete and fully bound AutoCAD set of improved record DWG exports.
- 1 corresponding TIFF or PDF copy of the above complete record set of documents. (Fig. D)
- 1 electronic TIFF or PDF image set of project specifications updated to include all product substitutions, addenda, drawings and graphics added to specification manuals
- Note: All document changes shall be highlighted by graphic clouds or revision symbols.
- "Record Set" identifier is to be added to all sheet and manuals title blocks

3b) Base Plan documents – To be sent simultaneously with the above Project Record documents transmission:

- 1 electronic and bound AutoCAD copy on a clearly labeled storage medium. (Fig. D)

REFERENCE FIGURES

Figure A - CAD Layer Structure for condensed Base Plan Drawings

It is important that the Base Plan drawing sets are constructed exactly as set forth below. It is important that ONLY THE DATA INFORMATION REQUESTED TO OCCUPY THESE LAYERS be included within this drawing set. The County set up these layers in the Hennepin County title block files earlier submitted to the Consultant for their use. There are 29 predetermined layers with an additional unassigned layer to be used at the discretion of the Consultant. The consultant may have to selectively remove project elements by type and consolidate layer information to achieve these required Base Plan layers.

	LAYER NAME	DESCRIPTION	COLOR	LINETYPE
1	0	BASE LAYER	WHITE	CONTINUOUS
2	A-CLNG-GRID	CEILING GRID	252	CONTINUOUS
3	A-CLNG-OVHD	OVERHEAD R.C.P. ITEMS, SOFFITS, SKYLIGHTS, CEILING OPENINGS	251	HIDDEN2
4	A-CORE-ELEM	EXT. STRUCTURAL/CORE WALLS, EXTERIOR- and OTHER DEDICATED DOORS, ELEVATORS, VERTICAL SHAFTS, and STAIRWELL ENCLOSURE WALLS ONLY	RED	CONTINUOUS
5	A-CORE-ELEM-STRS	STAIRWELL INTERNAL COMPONENTS: STAIRWAY TREADS, HANDRAILS, LANDINGS	251	CONTINUOUS
6	A-DOOR-INTR	ALL OTHER INTERIOR, NON-CORE ELEM. LAYER, DOORS	WHITE	CONTINUOUS
7	A-GLAZ-EXTR	EXTERIOR WALL WINDOWS, GLAZED CURTAIN WALLS	144	CONTINUOUS
8	A-GLAZ-INTR	INTERIOR DOOR SIDELITES, WALLS' BORROWED LITES, WINDOWS, WINDOW WALL SYSTEMS	144	CONTINUOUS
9	A-WALL-INTR	ALL NON-CORE INTERIOR WALLS, WALL SYSTEMS, SOLID PANEL DIVIDERS	WHITE	CONTINUOUS
10	E-LITE	LIGHTING FIXTURES, ALL TYPES w/ IDENTIFYING SHAPES. ADD ABBREV. TEXT FOR EM-TYPES	GREEN	CONTINUOUS
11	E-POWR-DEVC	HIGH & LOW VOLT DEVICES: VOICE, DATA, AND POWER	GREEN	CONTINUOUS
12	E-POWR-DISTR **	ELEC. DISTRIBUTION SHOWING ONLY P.O.P., PRIMARY AND SECONDARY PANEL LOCATIONS.	GREEN	CONTINUOUS
13	F-PROT-DISTR **	FIRE MAIN P.O.P., FIRE MAIN VERTICAL RISER(S), PRIMARY FIRE PANEL(S)	RED	CONTINUOUS
14	F-PROT-EQPM	SECONDARY FIRE PANELS, ALL SENSOR TYPES, SPRINKLER HEADS, EXTINGUISHERS	RED	CONTINUOUS
15	G-ANNO-TTLB	SHEET BORDER, TITLE BLOCK, AND SHEET TEXT	WHITE	CONTINUOUS
16	G-CODE	1 HR. OR GREATER FIRE/SMOKE SEPARATIONS AND OTHER RATED WALLS & RELATED TEXTS	RED	DASHDOT
17	I-EQPM	ALL OFFICE and BLDG. EQUIPMENT NOT COMPONENTS OF OTHER LAYER'S MAIN SERVICES	252	CONTINUOUS
18	I-FURN-MOVE **	MOVEABLE FURNITURE AT HEIGHTS BETWEEN WKSTN. PANEL TOPS DOWN TO 28" A.F.F.	15	CONTINUOUS
19	I-FURN-MOVE-OVHD-LO**	ALL OTHER FURNITURE COMPONENTS ABOVE OR BELOW WORKTOP HEIGHTS	15	HIDDEN2
20	I-FURN-FIXT	FIXED FURN., MILLWORK, CASEWORK. RELATED OBJECTS ABOVE OR BELOW USE HIDDEN2	06	CONTINUOUS
21	I-FURN-PNLS	WORKSTATION PARTITIONS	251	CONTINUOUS
22	M-HVAC-GRIL **	SUPPLY & RETURN DIFFUSERS, and TRANSFER GRILLE DEVICES. TEXT CLARIFY WALL TYPES	GREEN	CONTINUOUS
23	M-MECH-CONT	THERMOSTATS AND SENSORS RELATED TO HVAC OR B.A.S. CONTROLS	GREEN	CONTINUOUS
24	M-MECH-EQPM-DISTR **	PRIMARY ONLY MECHANICAL & HVAC EQUIPMENT, & PRIMARY RISERS ONLY	GREEN	CONTINUOUS
25	P-EQPM-DISTR	PRIMARY WATER & SEWER P.O.P., PRIMARY EQUIPMENT & PRIMARY RISER LOC'S. ONLY	WHITE	CONTINUOUS
26	P-FIXT **	PLUMBING FIXTURES, TOILET PARTITIONS, TOILET ACCESSORIES, ETC.	WHITE	CONTINUOUS
27	S-GRID	STRUCTURAL COLUMN GRIDS AND GRID DIMENSIONS	15	CENTER2
28	S-STRUC-MAIN **	STRUCTURAL PRIMARY COLUMNS, BEAMS AND KEY ELEMENT GRAPHICS ONLY	WHITE	CONTINUOUS
29	T-SERT-EQPM	SEC. SENSORS (ALL TYPES), CAMERAS, CONTROLLED HARDWARE INCL. ADA OPERATORS	144	CONTINUOUS
30	Consultant -	Defined	USER	DEFINED

** = Title does not conform to AIA - U.S. Nat'l. CAD Standard naming convention, version V6 of 2014.

"POP" = Point of Presence, where site services lines first connect to equipment inside the building's walls.

External Drawing References Requirements

It is common CAD drawing practice to utilize externally-referenced (X-refs.) drawing elements. When used, all X-refs. and all other referenced document images **must be electronically fully bound** to the main drawing. This is to insure access of the x-referenced material for a complete drawing without manipulation. The Base Plan shall not use externally referenced material.

Figure B - Example: Hennepin County Titleblock Information



HENNEPIN COUNTY MINNESOTA	
Facility Services Department	
Facility No. & Name: #120 - HSPHD NORTHWEST HUB	
Facility Address: ADDRESS ADDRESS CITY, MN 55XXX	
County Project No.: 7-DIGITXX	County Contract No.: 5-DIGITXX
County Project Manager Name: Mr./Ms. X X	
CAD Data: FILE NAME: 015-FP09.DWG	
Project Title: H.S.P.H.D. PROTOTYPE FLOOR TWO MODIF'S.	
Project Phase or Issue: DESIGN DEVELOPMENT	
 NORTH	
	
Drawing Title: CONSTRUCTION PLAN, ELEVATIONS & ENLARGED DETAILS	
Drawing Scale: Scale 1/8"=1'-0", or as otherwise noted	
Sheet A1.2 of 12	

Figure C -
 Sample of CD File List Table
 Sample of Non-Conforming Layer Table

Sample Of CD File List Table	
Folder – Floor Plans	
File Name	Description
Aflor1.dwg	Model X-Ref Of First Floor Plan
File-List.doc	Listing Of All CD Contents And Descriptions
Aflor2.dwg	Model X-Ref Of Second Floor Plan
Non-Conforming Layers.doc	Listing Of All Non-Conforming Drawing Layers

Sample Of Non-Conforming Layer Table	
Drawing Title	
Layer Name	Description
M-EQPT	Special Mechanical Equipment
PERSONNEL	Staff Names

Figure D -
 Sample of Clearly Labeled CD or DVD case

HENNEPIN COUNTY PROJECT TITLE	
COUNTY PROJECT	COUNTY CONTRACT
NUMBER	NUMBER
HENNEPIN COUNTY PROJECT MANAGER	
FACILITY NAME	
CONSULTANT NAME	
SUBMITTAL PHASE and DATE, or	
CONSTRUCTION COMPLETION DATE	

Hennepin County Facility Services Department
REQUIREMENTS FOR A CAPITAL PROJECT SCHEMATIC DESIGN REPORT

The Format should be 8½ x 11 with binding at 11- inch edge. Plan sheets may be 8½ x 11 or 11 x 17 folded to 8½ x 11. Provide heavy weight cover, front and back with appropriate graphics and title information. Provide one unbound “master” copy and six bound copies after a draft has been approved by the Owner. Provide an electronic copy of all schematic design report documents in the original format of the software in which they were created (e.g. Word files, Excel files, drawing files) and in addition, provide an electronic copy of all schematic design report documents integrated into a single, viewable and printable file (e.g. Adobe Acrobat).

This Report, the summation of schematic design phase activities by the consultant design team, should, at a minimum, contain the following information and data when applicable to the project:

1. Table of Contents
2. Consultant Team Identification
3. Introduction/Executive Summary to include project scope/design objective, a brief explanation of the design process and an overview of the design solution, project cost estimates and project schedule summary.
4. Schematic Design Narrative to include rationale, size/area, zoning/density, vehicular/pedestrian movement and access, surface treatments, landscaping, signage, and lighting.
5. Architectural Form and Design to include rationale, style and function.
6. Structural System to include type/analysis, and modularity.
7. Interior Systems to include core/circulation/modularity, special flooring/modularity/access, partitioning/modularity, furnishings and furniture/modularity, and acoustic design/standards.
8. Mechanical Systems schematic design shall include concept descriptions for all systems including: utilities, energy sources, HVAC, controls, plumbing, fire protections and emergency systems, and HVAC systems
9. Electrical Systems schematic design shall include concept descriptions for all systems including: energy sources, power distribution, lighting, communications, alarms, security and emergency systems, and HVAC systems
10. Special Systems as required.
11. Design Drawings to include site context/master plan, floor plans including preliminary furniture layouts, elevations, building sections, and perspective/character sketches as required.
12. Technical Specifications to include principal components of General Requirements and Sections, Divisions 2 through 16, in outline form.
13. Space Utilization to include area tabulations and program tabulations.
14. Construction and Project Cost Estimates to include assumptions and/or methodology, itemization of cost by major building system and per square foot, and contingencies.
15. Project Schedule delineating time/task through anticipated occupancy.

Hennepin County Facility Services Department
REQUIREMENTS FOR A CAPITAL PROJECT DESIGN DEVELOPMENT REPORT

The Format should be 8½ x 11” with binding at 11-inch edge. Plan sheets may be 8½ x 11 or 11 x 17 folded to 8½ x 11. Provide heavy weight cover, front and back with appropriate graphics and title information. Provide one unbound “master” copy and six bound copies after a draft has been approved by the Owner. Provide an electronic copy of all design development report documents in the original format of the software in which they were created (e.g. Word files, Excel files, drawing files) and in addition, provide an electronic copy of all design development report documents integrated into a single, viewable and printable file (e.g. Adobe Acrobat).

This Report, the summation of design development phase activities by the consultant design team, should, at a minimum, contain the following information and data:

1. Consultant Team Identification
2. Table of Contents
3. Introduction/Executive Summary to include project scope/design objective, a brief explanation of the design process and an overview of the design solution, project cost estimates and project schedule summary.
4. Program Summary outline similar to that described for the Schematic Design report, but adding the building infrastructure requirements (mechanical, electrical, and communication systems). Include a chart or table comparing the original program needs with the spaces and systems provided in the Design Development plans. If there are differences from the Schematic Design program, note the reasons.
5. Citation of all applicable codes, statutes, regulations/ordinances by title, edition and date.
6. Code Analysis which subjects the facilities to scrutiny against all pertinent code elements – such as occupancy, type of construction, quantity limits, fire protection, life safety, etc., -- to yield an orderly listing of requirements which can serve as a design checklist.
7. Site Development in the form of a concept statement and to indicate property limits, site area, vehicular and pedestrian movement patterns and access points, site improvements, surface treatments, lawns and planting, external security, signage, lighting, etc., site plan.
8. Building Systems analysis beginning with a concept statement followed by descriptions of foundation system, superstructure, design loads, roof structure, building envelope, curtain wall systems, vertical transportation, etc.
9. Interior Systems analysis beginning with a concept statement followed by descriptions of floor surfaces, wall and partition systems, ceiling systems, storage, casework, etc.
10. Material, Finish and Color Schedule both exterior and interior, which articulates in an abbreviated manner, the visual aspect of the facility.
11. Special Systems analysis beginning with a concept statement followed by descriptions of the system and its major elements.

Hennepin County Facility Services Department
REQUIREMENTS FOR A CAPITAL PROJECT DESIGN DEVELOPMENT REPORT

12. Mechanical Systems design shall include Schematic Design information restated or revised along with diagrams and floor plans showing sizes for major components such as boilers, chillers, air handling units, trunk ducts, plumbing risers, etc. Expand design performance standards to include building envelope characteristics. Expand control descriptions to final specification form.

Develop an operating costs analysis which itemizes heat loss, heat gain and the energy consumption costs for heating, cooling and ventilation on an annual basis. Coordinate the analysis with the electrical portion to avoid duplication of costs.

13. Electrical Systems design shall include Schematic Design information restated or revised along with diagrams and floor plans showing sizes for major components such as transformers, switchgear, bus duct, etc. Expand design performance standards to include primary services, distribution power levels, lamping, motor power factors, grounding, etc.

Develop an operating costs analysis which itemizes connected loads, power factors, and lighting, power, heating, ventilating, cooling and other electrical energy consumption costs on an annual basis. Coordinate the analysis with the mechanical portion to avoid duplication of costs.

14. Area Summary in tabular form indicating gross square feet, building/floor common areas, rentable square feet, usable square feet and net program area. Net program area shall be listed on a room by room basis. (See attached definitions.)
15. Building Floor Plans including furniture layouts.
16. Building Elevations and Sections.
17. Exterior and Interior perspective Drawings (as appropriate).
18. Outline specifications to include bidding requirements, conditions of the contract, general requirements and technical specifications.
19. Estimated Cost Summary to include costs categorized into building systems with major elements itemized within each system.
20. Project Schedule with time and tasks indicated through anticipated occupancy.

Enclosure:

- County Space Definitions
- Heating System Schematic Diagram
- Cooling System Schematic Diagram
- Mechanical Design/Calculation Summary
- Electrical Service and Distribution Diagram
- Electrical Design/Calculation Summary

Hennepin County Facility Services Department
REQUIREMENTS FOR A CAPITAL PROJECT DESIGN DEVELOPMENT REPORT

Hennepin County Space Definitions

A. GROSS SQUARE FEET (GSF):

Gross square feet (GSF) refers to the entire floor area, or “footprint”, of that particular floor or building level. The total GSF is the sum of all floor levels within a building, including basement levels, garage parking, and all mechanical/electrical rooms. The floor area is measured to the outside face of the exterior walls. Gross square feet is used most often for the purposes of new construction cost references and zoning requirements.

B. USEABLE SQUARE FEET (RSF):

Rentable area is applicable to both leased buildings and owner-occupied buildings. Rentable square feet (RSF) is calculated by measuring to the inside of perimeter (exterior) walls, excluding the area of any major vertical floor penetrations. (such as stairways, elevator shafts, and mechanical shafts). RSF does include all common support spaces within a building, such as public restrooms, M/E equipment rooms, required corridors, shared conference or meeting rooms, elevator and entry lobbies, and other spaces serving the building occupants. The RSF is always less than the GSF of a building, and more than the usable square feet (USF) noted below. RSF is typically the basis for the calculation of annual rent payments, which includes the useable area plus a pro-rata share of the building common support spaces.

- Typical RSF / GSF ratio ranges from 0.75 to 0.85

C. USABLE SQUARE FEET (USF)

Usable area measure the portion of the building or floor that is available for occupants after deducting the common support areas outlined above. Usable square feet (USF) is the actual net floor area that is used for the purposes of programming, planning and space allocation. The USF does include interior circulation space to allow access to the individual program components such as private offices, workstations, conference rooms, storage, and other spaces.

- Typical USF / RSF ratio ranges from 0.70 to 0.85
- Typical USF / GSF ratio ranges from 0.60 to 0.75

D. ASSIGNABLE AREA (Net Program Area)

The actual area within a Department’s space / suite after deducting the internal circulation areas from the Useable Areas. Assignable Area (NSF) refers to the amount of the individual office, workstation, storage, conference room, copy / work area and filing spaces called for in the new program of space requirements used for planning purposes. Typically, the internal circulation amounts to approximately 30% of the Useable Area, but may vary depending on building type, the actual layout of a space and overall efficiency of the plan.

Hennepin County Facility Services Department
REQUIREMENTS FOR A CAPITAL PROJECT DESIGN DEVELOPMENT REPORT

E. FLOOR COMMON AREA (special use area)

The areas on a floor such as restrooms, janitorial closets, electrical and telephone rooms, mechanical rooms, elevator lobbies, and public corridors which are typically fixed elements available primarily for the use of Departments on that floor.

F. BUILDING COMMON AREA (special use area)

The areas of the building that provide services to County Departments but which are not included in the Useable Square Feet of any specific Department. These areas may include, but shall not be limited to, main and auxiliary lobbies, atrium space at the level of the finished floor, shared conference rooms, food service facilities, health or fitness centers, daycare facilities, locker or shower facilities, mail rooms, fire control rooms, fully enclosed courtyards outside the exterior walls, and building core and service areas such as fully enclosed mechanical or equipment rooms. Specifically excluded from the Building Common Area and floor Common Areas, parking space, portions of loading docks outside of the building line, and Major Vertical Penetrations. This space is not considered as general office space, or not readily convertible to multi-purpose office space. Building Common Areas are intended for special purpose, non-office use.

Hennepin County Facility Services Department
REQUIREMENTS FOR A CAPITAL PROJECT DESIGN DEVELOPMENT REPORT

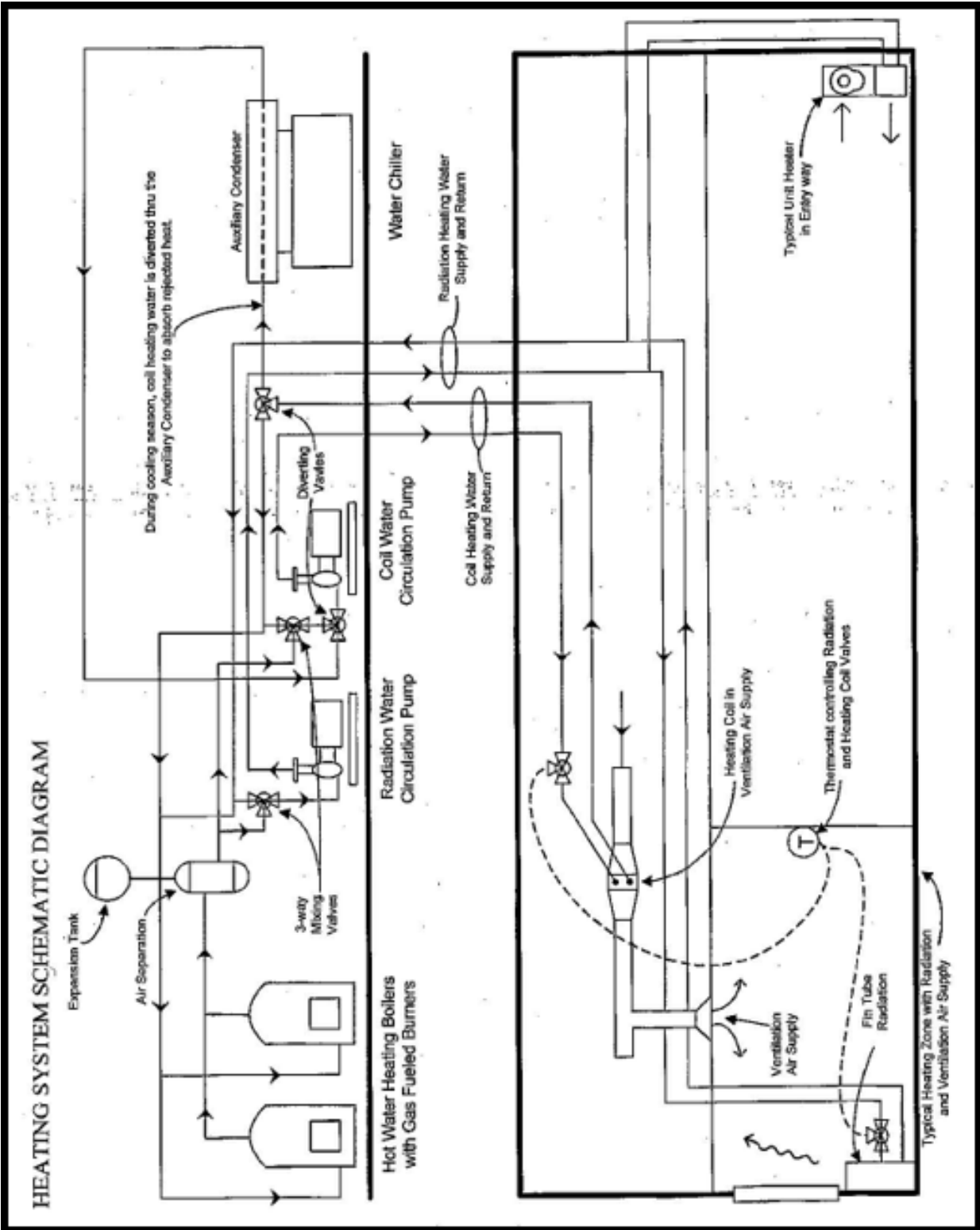

Hennepin County Facility Services Department
REQUIREMENTS FOR A CAPITAL PROJECT DESIGN DEVELOPMENT REPORT

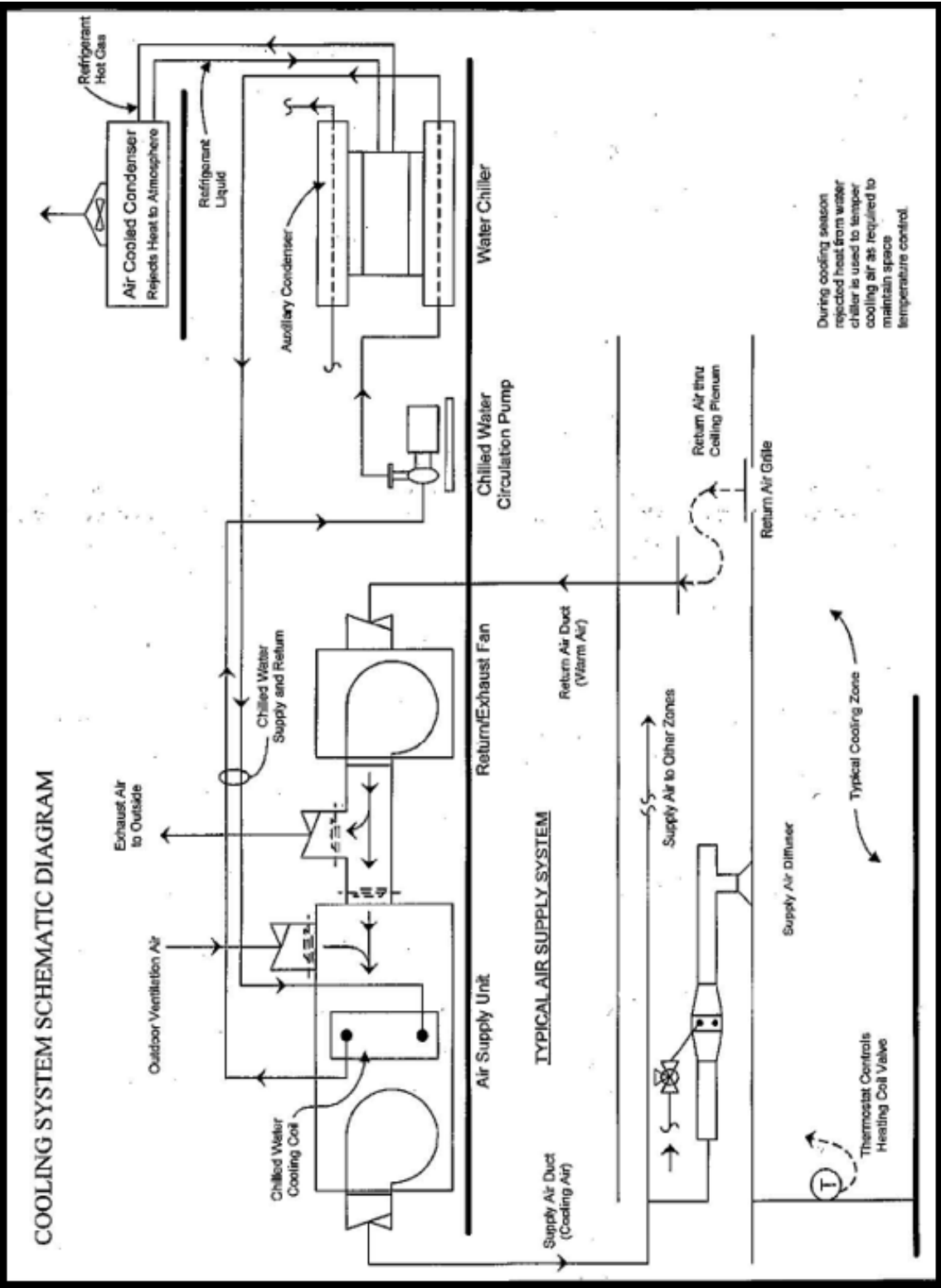

Hennepin County Facility Services Department
REQUIREMENTS FOR A CAPITAL PROJECT DESIGN DEVELOPMENT REPORT

Mechanical Design / Calculation Summary

Heating and Ventilation Consumption

Month	Heating Degree Days	Heating Load BTU X 10 ⁶ (Therms)	Fuel Consumption - lbs. of steam - cu. Ft. natural gas - gal. of oil - etc.
January			
February			
March			
April			
May			
June			
July			
August			
September			
October			
November			
December			
TOTAL			

Total Annual Heating Load _____ BTU X 10⁶

Annual Heating Fuel Consumption _____ BTU X 10⁶

Annual Heating Fuel Consumption (lbs. of steam, etc.) _____

Annual Heating Fuel Consumption _____ BTU/SF

Hennepin County Facility Services Department
REQUIREMENTS FOR A CAPITAL PROJECT DESIGN DEVELOPMENT REPORT

Mechanical Design / Calculation Summary

Heat Gain Summary

<u>Conduction and Solar Load</u>	<u>BTU/HR</u>
Walls	_____
Glass	_____
Roof	_____
Occupants (state number)	_____
Sensible	_____
Latent	_____
Miscellaneous	_____
Sensible	_____
Latent	_____
Ventilation	_____
Lighting	_____
Miscellaneous Electric	_____
<u>Ventilation Fan Heat</u>	_____
TOTAL Heat Gain	_____

Equivalent Full Load Hours	_____
Total Annual Cooling Load	_____ BTU X 10 ⁶
Total Annual Cooling Load/SF	_____ BTU/SF
Total Annual Cooling Cost	\$_____ for the year
Total Annual Cooling Cost/SF	\$_____ /SF
	@ \$_____ /Unit of Energy
	@ \$_____ /Unit of Demand

Hennepin County Facility Services Department
REQUIREMENTS FOR A CAPITAL PROJECT DESIGN DEVELOPMENT REPORT

Mechanical Design / Calculation Summary

Cooling and Ventilation Consumption

Month	Cooling Degree Days	Cooling Load BTU X 10 ⁶ (Therms)	Energy Consumed		
			Tons of Chilled Water	KWH	Etc.
January					
February					
March					
April					
May					
June					
July					
August					
September					
October					
November					
December					
TOTAL					

Total Annual Cooling Load _____/BTU X 10⁶

Annual Energy Consumption _____/BTU X 10⁶

Annual Ton-Hr / BTU X 10⁶ _____ / _____
 Annual KWH / BTU X 10⁶ _____ / _____
 Annual _____/BTU X 10⁶ _____ / _____

Annual Cooling Energy Consumption _____/BTU X 10⁶

Hennepin County Facility Services Department
REQUIREMENTS FOR A CAPITAL PROJECT DESIGN DEVELOPMENT REPORT

Mechanical Design / Calculation Summary

Mechanical Design Criteria / Energy Cost Analysis

Design Weather Parameters

- City Name – Location
- Latitude / Elevation
- Summer Design Dry Bulb – Temperature Degree F
- Summer Design Wet Bulb – Temperature Degree F
- Daily Temperature Range
- Winter Design Dry Bulb Temperature
- Solar Haze Factor

Building Area – Square Feet

Summer Inside Design Condition – DB/WB Degrees F

Winter Inside Design Condition – DB/WB Degrees F

Heat Loss Summary

<u>Conduction</u>	<u>BTU/HR</u>
Walls	_____
Glass	_____
Doors	_____
Edge	_____
Roof	_____
Ventilation	_____
<u>Infiltration</u>	_____
TOTAL Heat Loss	_____

Total Annual Degree Days _____

Total Annual Heat Loss _____ BTU X 10⁶

Total Annual Heat Loss/SF _____ BTU/SF

Total Annual Heat Cost \$ _____ for the year _____

Total Annual Heat Cost/SF \$ _____/SF

@ \$ _____/Unit of Energy

@ \$ _____/Unit of Demand

Hennepin County Facility Services Department
REQUIREMENTS FOR A CAPITAL PROJECT DESIGN DEVELOPMENT REPORT

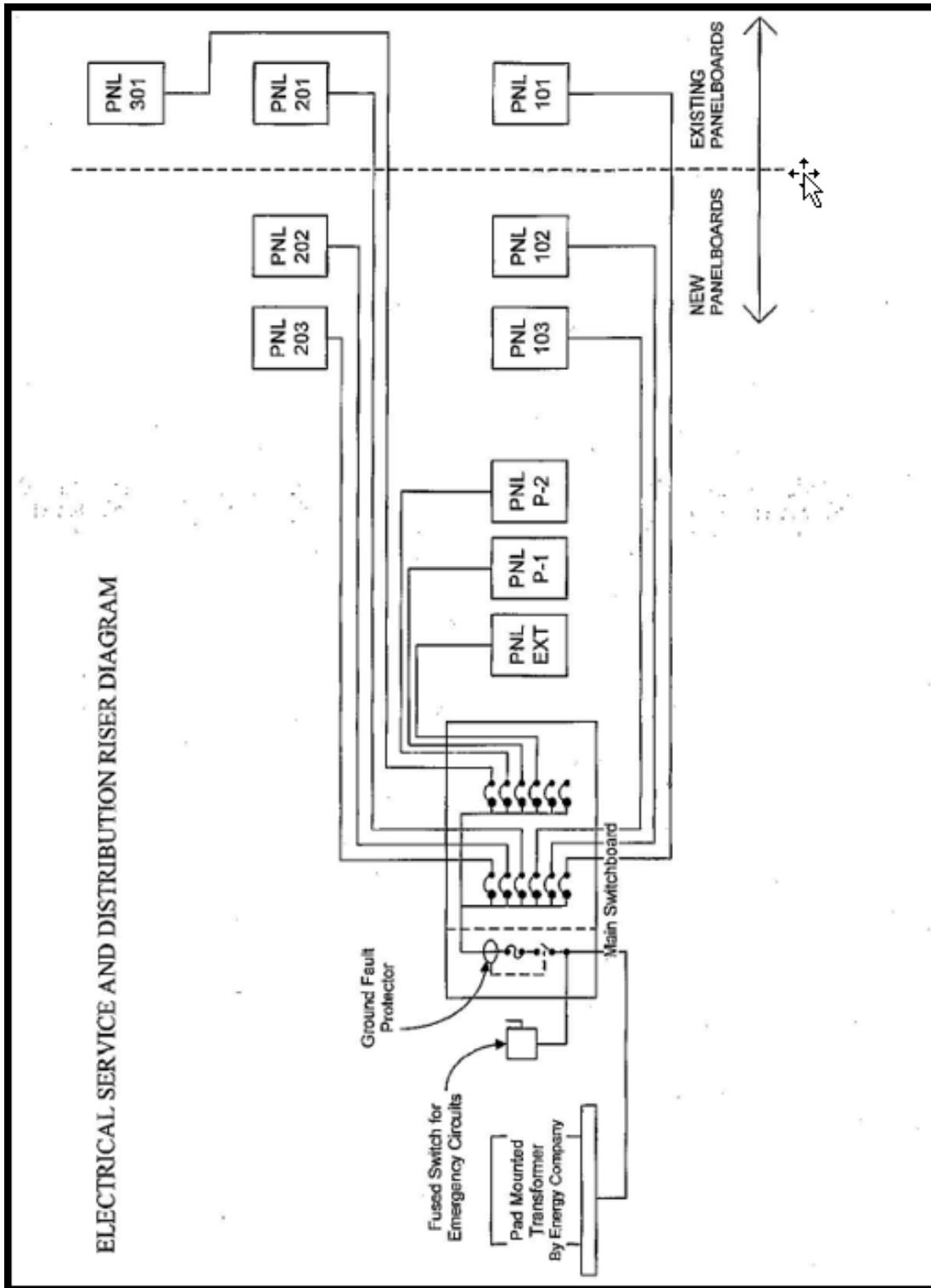

Hennepin County Facility Services Department
REQUIREMENTS FOR A CAPITAL PROJECT DESIGN DEVELOPMENT REPORT

Electrical Design / Calculation Summary

Electrical Design Criteria / Energy Cost Analysis

Lighting Levels

- a. Offices _____footcandles
- b. Corridors _____footcandles
- c. Equipment areas _____footcandles
- d. _____footcandles
- e. _____footcandles
- f. _____footcandles

Emergency Lighting (percent of fixtures)

- a. General Office Lighting _____%
- b. Corridor Lighting _____%
- c. Exit Stairway Lighting _____%
- d. Exit Signs _____%
- e. Equipment Rooms _____%
- f. _____%
- g. _____%
- h. _____%
- i. _____%

Hennepin County Facility Services Department
REQUIREMENTS FOR A CAPITAL PROJECT DESIGN DEVELOPMENT REPORT

Operational Cost Analysis – Electrical Utilities

Month		Cool	Heat	Vent	Lights	Equipment	TOTAL
January	Energy Demand Cost						
February	Energy Demand Cost						
March	Energy Demand Cost						
April	Energy Demand Cost						
May	Energy Demand Cost						
June	Energy Demand Cost						
July	Energy Demand Cost						
August	Energy Demand Cost						
September	Energy Demand Cost						
October	Energy Demand Cost						
November	Energy Demand Cost						
December	Energy Demand Cost						
TOTAL	Energy Demand Cost						

Analysis for the calendar year _____. Total Cost per Sq. Ft. _____